

MANUFACTURED IN:



TECHNICAL MANUAL

ISOCOP Multifunction



TABLE OF CONTENTS

ISOCOP Multifunction	4
<i>Geometric features.....</i>	<i>4</i>
<i>Metal facings</i>	<i>4</i>
<i>Protection of the pre-painted faces</i>	<i>4</i>
<i>Insulation.....</i>	<i>5</i>
<i>Panel weight.....</i>	<i>5</i>
<i>Static features</i>	<i>5</i>
<i>Joint</i>	<i>7</i>
<i>Tolerances (annex D EN 14509)</i>	<i>7</i>
<i>Reaction to fire (EN 13501-1).....</i>	<i>7</i>
<i>Broof.....</i>	<i>8</i>
<i>Water permeability</i>	<i>8</i>
<i>Restrictions of use</i>	<i>8</i>
<i>General design instructions.....</i>	<i>8</i>
<i>Thermal expansion</i>	<i>10</i>
<i>Fastening instructions</i>	<i>11</i>
<i>Multifunction applications.....</i>	<i>17</i>
<i>Assembly instructions</i>	<i>18</i>
<i>Package composition</i>	<i>19</i>
<i>Transport and storage.....</i>	<i>20</i>
<i>Packaging.....</i>	<i>21</i>
<i>Durability</i>	<i>21</i>
<i>Maintenance.....</i>	<i>21</i>
<i>Safety and disposal.....</i>	<i>21</i>
Annex A.....	22
Annex B.....	24
<i>Suction cup lifters.....</i>	<i>24</i>
Annex C.....	29
<i>Building details</i>	<i>29</i>

ISOCOP Multifunction

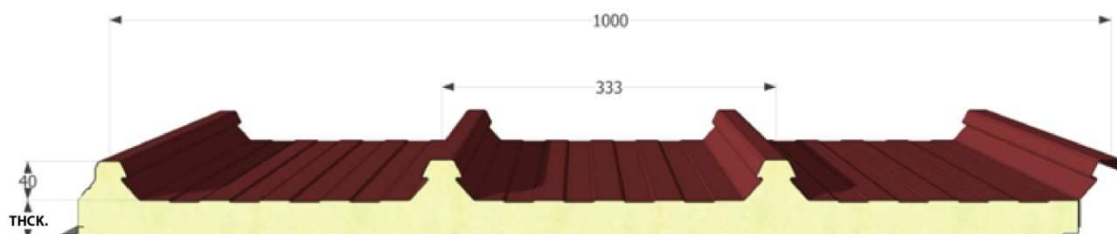

Self-supporting 4-rib roof sandwich panel with polyurethane foam insulating core. The panel was designed for application on sloped roof pitches or on walls. Thanks to the special rib shape the roof or wall may be integrated with specifically designed accessories in simple, practical steps.

GEOMETRIC FEATURES

	ISOCOP Multifunction
Length	Up to maximum transportable
Useful Pitch (mm)	1000
Insulating Thickness (mm)	30, 40, 50, 60, 80, 100, 120
External face	Ribbed metal sheet with 4 ribs: -rib height 40 mm -rib pitch 333 mm
Internal face	micro-ridged lightly profiled metal sheet

METAL FACINGS

- SENDZIMIR system hot dip galvanised steel by continuous process (UNI EN 10346) and pre-painted by means of a coil coating continuous process with different painting cycles based on end use (see: "Guide to Choosing Pre-painted").
- 3000 or 5000 series aluminium alloys with pre-painted finish with the cycles mentioned in the previous point, with a natural or embossed effect.
- Stainless steel AISI 304, 2B finish, according to EN 10088-1.
- In case of aluminium facings, these must be preferably applied on both sides: in fact, if different materials are used on the two sides, the panel may distort and bend due to the different thermal expansion coefficients of the faces.
- For stainless steel facings, one should take into account the possible appearance of flaws that are highlighted by such reflecting surfaces.

PROTECTION OF THE PRE-PAINTED FACES

All pre-painted metal facings are supplied with an adhesive polyethylene protective film that prevents damage to the paint layer. If the material is specifically requested without protective film, Isopan assumes no liability in case of damages to the paint. The protective film that covers the pre-painted panels must be completely removed during assembly and, in any case, within sixty days after the material preparation.

It is also recommended not to expose the panels covered by a protective film to direct sunlight.

INSULATION

Made with rigid polyurethane foam, having the following physical and mechanical features:

- Compressive strength ≥ 0.11 MPa (at 10% of deformation)
- Tensile strength ≥ 0.10 MPa according to EN 826
- Shear strength ≥ 0.10 MPa according to EN 826
- Thermal conductivity coefficient $\lambda = 0.022$ W/mK
- The 95% closed cells guarantee an anhygroscopic structure
- Operating temperature:

minimum	- 40 °C
maximum	+ 80 °C

Foaming agent: N-Pentane in accordance with the Montreal protocol

Thermal transmittance coefficient U*

Panel thickness (mm)	30	40	50	60	80	100	120
U [W/m²K]	0.71	0.54	0.44	0.37	0.28	0.22	0.19

* Mandatory for CE marking of double skin metal faced sandwich panels according to EN 14509.

Thermal resistance coefficient R

Panel thickness (mm)	30	40	50	60	80	100	120
R [m²K/W]	1.41	1.85	2.27	2.70	3.57	4.55	5.26

PANEL WEIGHT

Sheet thickness (mm)		Nominal panel thickness (mm)						
		30	40	50	60	80	100	120
0,4/0,4	kg/m ²	8,3	8,7	9,1	9,2	10,4	11,1	11,9
0,5/0,5	kg/m ²	10,1	10,5	10,9	11,4	12,1	12,9	13,7
0,6/0,6	kg/m ²	11,9	12,2	12,7	13,1	13,9	14,7	15,5

STATIC FEATURES

ISOCOP MULTIFUNZIONE double skin metal faced panels are self-supporting according to the UNI EN 14509 definition. "...panel capable of supporting, by virtue of its materials and shape, its own weight and in case of panel fastened to spaced structural supports, all applied loads (snow, wind, air pressure), and transmitting these loads to the supports.", depending on the type of metal supports, their thickness and the thickness of the thermal insulating core.

The resistance values refer to a panel assembled horizontally and subject to the action of a distributed load; the calculation method used by Isopan does not consider the thermal effects, which are verified by the designer. Depending on the weather conditions of the installation location and the colour of the external face, if the designer feels a detailed verification of the stresses caused by thermal actions and long-term effects is necessary, he/she should contact the Isopan Technical Office. The designer is still responsible for checking the fastening systems, based on their number and the way they are placed.

Below are some examples of indicative load bearing tables:

The indications included in the following tables doesn't take into account the thermal load effects. Furthermore, the indicative values reported may not be used to replace the project calculations drawn up by a qualified technician, who will have to validate these instructions in accordance with the laws in the country of installation of the panels.

- panel on two supports:

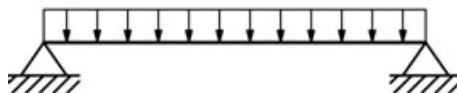

STEEL SHEETS 0.5/0.5 mm - Simple support 120 mm							
UNIFORMLY DISTRIBUTED LOAD [kg/m ²]	NOMINAL PANEL THICKNESS mm						
	30	40	50	60	80	100	120
	MAXIMUM SPAN cm						
80	295	330	370	400	470	530	590
100	260	305	330	370	430	490	540
120	220	275	300	330	395	435	490
140	195	250	270	295	350	410	460
160	170	220	250	270	320	380	420
180	150	200	230	245	285	340	400
200	140	180	210	225	260	310	360
220	125	165	200	210	240	280	330
250	110	145	180	195	215	250	280

STEEL SHEETS 0.6 / 0.5 mm - Simple support 120 mm							
UNIFORMLY DISTRIBUTED LOAD [kg/m ²]	NOMINAL PANEL THICKNESS mm						
	30	40	50	60	80	100	120
	MAXIMUM SPAN cm						
80	310	340	390	420	490	550	610
100	260	315	350	380	440	500	550
120	220	290	330	355	400	450	500
140	195	250	295	320	380	420	460
160	170	220	270	290	340	390	430
180	155	200	245	265	310	360	400
200	135	180	225	250	285	330	380
220	125	175	200	230	265	305	350
250	115	150	180	210	235	270	310

JOINT

The joint is fitted with a continuous sealing gasket, inserted during production. The joint shape is specifically designed to prevent leaks and reduce thermal bridges.

In heavy-duty conditions, to try to prevent condensate, an optional gasket can be put in to increase joint airtightness (as shown below); this element can be supplied by Isopan and must be installed directly on site during panel installation.

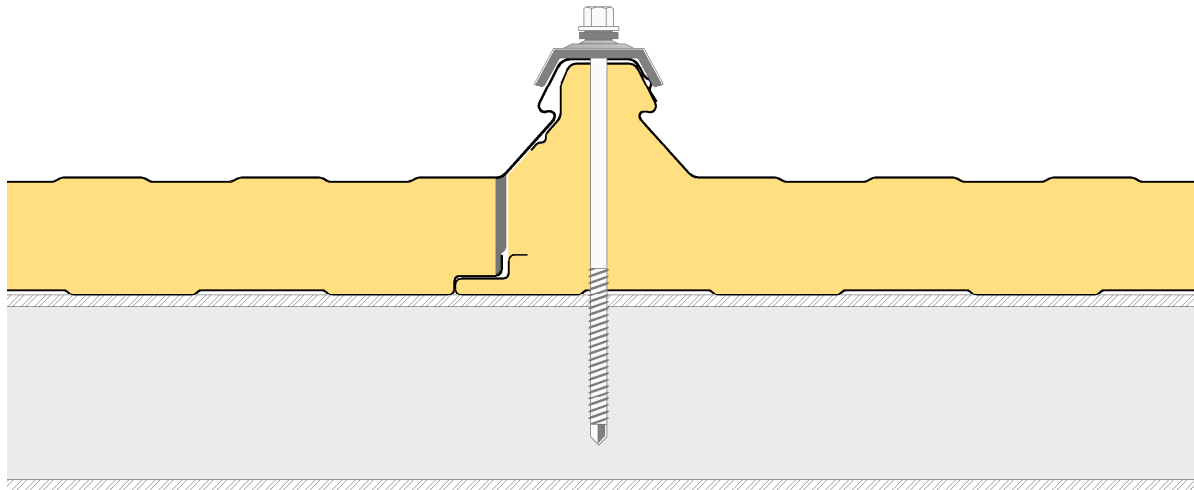

TOLERANCES (ANNEX D EN 14509)

- Metal sheet thickness: according to the reference standards for the products used
- Panel thickness: nominal, ± 2 mm
- Length: if ≤ 3000 mm ± 5 mm; if > 3000 mm ± 10 mm

REACTION TO FIRE (EN 13501-1)

The reaction to fire indicates the degree to which a material participates in the fire to which it is subjected.

The European reference standards to classify the reaction to fire of construction material is **EN 13501-1** (Fire classification of construction products and building elements). This standard specifies:

Euroclasses: the standard distinguishes seven classes, with increasing contribution to fire, from A1 (non-combustible product) to F (product not tested/not classified).

Smoke: smoke opacity growth speed

- **s1** no smoke emission
- **s2** low smoke emission
- **s3** strong smoke emission

Burning droplets: fall of burning particles

- **d0** no burning particles
- **d1** few burning particles
- **d2** many burning droplets

The fire classification of the panel depends on the type of polyurethane foam used and the thickness of the insulation; for further information, please refer to the Isopan catalogue, the website www.isopan.com or contact the Technical Department.

BROOF

The external fire resistance classification system for roofing (Broof) is based on four test levels that simulate different fire triggering and development conditions:

- **t1:** burning brand alone
- **t2:** burning brand and wind
- **t3:** burning brand, wind and solar radiation
- **t4:** burning brand, wind and supplementary radiant heat

The panel can be Broof certified; please contact the Isopan Technical Department to check what classifications have been obtained based on the type of insulating material and metal support.

WATER PERMEABILITY

The resistance of a sandwich panel assembly to driving rain under air pressure must be subjected to testing according to **EN 12865**.

The panel may be certified based on water permeability classification; please contact the Isopan Technical Department to check what classifications have been obtained based on the type of joint.

RESTRICTIONS OF USE

- A thermohygroscopic check should be performed during the design stage. In certain conditions (e.g. high indoor humidity level) condensation can appear on the internal face of the panel with consequent dripping inside the building. If these conditions persist long enough, they can accelerate the natural degradation of the organic facing of the face itself.
- **Due to solar radiation, the external face of the panel can reach relatively high temperatures. In some cases, it can reach a temperature of 80+90°C.** A high temperature gradient should cause the panel deflection the panel and wrinkle the metal sheet. The occurrence of the problem may be limited with an accurate design, taking into account environmental conditions, length, colour of the panels and the number of fastening elements. (**See the "Thermal expansion" section**).

GENERAL DESIGN INSTRUCTIONS

The roof panels generally require, during the design phase, a load-bearing structure able to absorb the external loading stress that will not submit the metal supports of the panels to excessive and permanent distortions to the detriment of their basic characteristics. When choosing panel types in the design stage, some parameters related to environmental actions should be considered, such as:

- **Wind action:** depends on the climatic zone of the building installation; the values vary depending on the wind speed, with consequent greater or lesser load pressure on the exposed surfaces (affects the type and number of panel fastening systems).
- **Snow load:** depends on the elevation above sea level compared to the one at the building construction site. The formation of water puddles resulting from snowmelt must be taken into account, which can expose the overlapping joints to being pressed under a load of water and possibly create infiltrations. It is recommended to implement appropriate tinwork systems (or suitable constructive measures) to ensure normal water run-off.
- **Thermal stress:** largely depends on the colour of the external surface of the panel and the building exposure, and can induce significant system deformations.
- **Atmospheric corrosion:** depends on the environment where the panels are installed (marine, industrial, urban, rural); mainly affects the degree of corrosiveness on the panel surfaces. In this regard, suitable metallic or organic facings should be chosen (refer to the available documentation or contact the Isopan Technical Department).

- **Rainfall:** the degree of rainfall affects the slope angle of the roof pitch; in order to ensure normal water run-off and to prevent the metal supports from oxidising, the slope angle of the panels must be chosen on the basis of two types of construction:
- Roof without intermediate overlapping joints;
- Roof with intermediate overlapping joints.

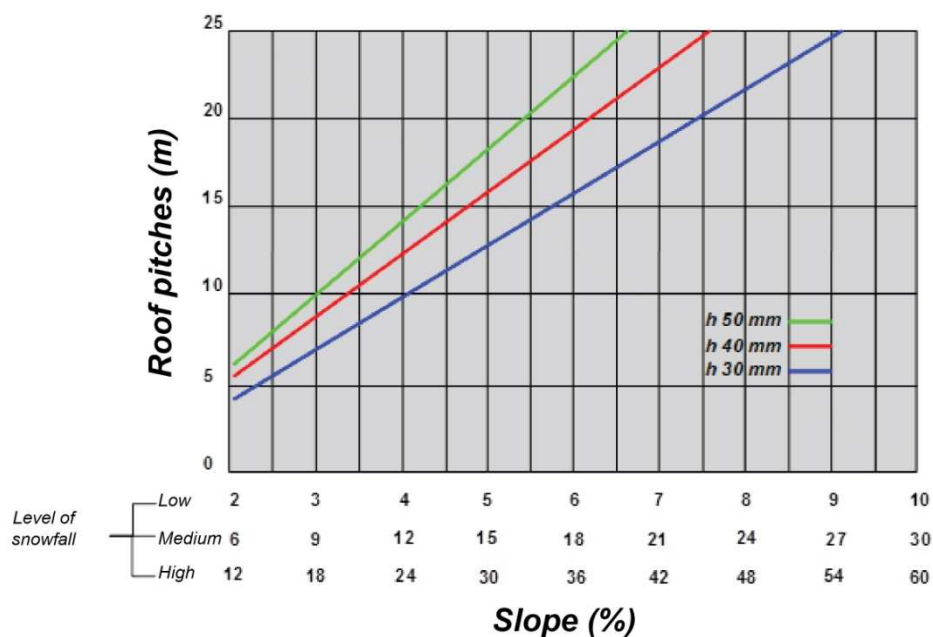

In the former case, the minimum slope, in relation to the climatic area and the rib height, can be taken from the **Slope diagram**. We recommend (in the event of low or average level of snowfall) a slope no less than 7%.

In the event of roofs built with intermediate overlapping joints, the slope can be taken from the Slope diagram, increasing it (for roof pitches with slope <25%) by a value equal to $0.2 \cdot L$, with L = length of the roof pitch (expressed in metres). The presence of intermediate overlapping joints depends on the slope, the level of snowfall and exposure to wind. Under normal weather conditions, the overlap values generally used are:

Slope (%)	Overlap (mm)
$7 < P \leq 10$	250
$10 < P \leq 15$	200
$P > 15$	150

Gutter drip edge: Isopan, in consideration of standard **UNI 10372** and the rules of best practice, recommends requesting the gutter arrangement in order to make a drip edge and prevent any leaks into the insulating material or inside the building.

This solution is required to prevent premature panel head decay since, if exposed to stagnating water, the metal might oxidise and the faces might detach from the insulating mass in places.

After the drip edge, it is recommended to protect the heads (insulation and faces) with Isopan liquid sheath that can be applied on-site.

In order to make up for possible lack of material due to damages during handling and assembly, Isopan recommends procuring spare panels (quantity equal to approximately 5% of the total).

THERMAL EXPANSION

All the materials used to build the roofs, especially metals, are subject to **thermal expansion and contraction** phenomena, due to temperature changes. The stresses due to metal sheet thermal expansions act on the roof and can cause functional and structural product anomalies, particularly in case of:

- Significant panel length ($L > 8000$ mm);
- Solar radiation;
- Medium and dark colours;
- High panel thickness.

These stresses are exerted on the head of the fastening element, with bend and shear stress in the event of fastening on rib. These are important parallel to the ribbing, as transversally, they are cancelled out by the flexibility of the metal sheet profile itself.

Material	Thermal expansion coefficient ($^{\circ}\text{C}^{-1}$)
Aluminium	23.6×10^{-6}
Steel	12.0×10^{-6}
Stainless steel AISI 304	17.0×10^{-6}

-Linear thermal expansion coefficient values-

Type of facing		Surface temperature ($^{\circ}\text{C}$)	
		Min.	Max.
Insulated	Light	-20	+60
	Dark	-20	+80

Where "insulated" means that an insulating core is inserted between the external sheet and the structure; "light or dark" means the surface colour of the sheet.

-Temperature range-

For high surface temperature values, linear extension of the metal support must be absorbed by the system. If this is not so, tensions occur that discharge near the sheet section changes by effect of the shape variation. Furthermore, cyclical temperature changes associated to day-night or freeze-thaw differences cause uncontrollable cyclical stresses that fatigue the support elements. These stresses can exceed the material yield point (formation of bubbles) or the failure limit. The effect of this phenomenon is the formation of fatigue cracks, initially not visible, that cause cracking on the face, undermining the product's structural features and water tightness. This problem can be overcome by adopting the requirements:

- Calculate in advance the deformation induced on the panel by the thermal expansion.
- Do not use dark colours on long panels.
- Use suitable thickness of the metal supports (minimum 0.6 mm for steel faces).
- Segment the panels.
- Suitable fastening texture (see proposed Isopan fastening in the "Roofing panel fastening" section in this manual).

In the event of **Aluminium** panel installation, we recommend using stainless steel screws with cap and specific washer.

If the pitch length requires the use of several panels, the heads of the panels must be spaced by about 5-10 mm (minimum distance in the hotter season, maximum distance in the colder season), taking care to put a flexible gasket between the heads to prevent condensate from forming.

For anything that is not expressly indicated, refer to standard **UNI 10372** and the **Isopan General Sales Conditions** and annexes.

FASTENING INSTRUCTIONS

The purpose of the fastening elements is to efficiently anchor the panel to the load-bearing structure; the type of fastening unit depends on the type of face. The number and position of the fastening elements must guarantee resistance to the stresses induced by dynamic loads, which can also exist in depression.

Isopan recommends fastening at the top of the ribs; the possibility of fastening at the bottom of the rib is not to be ruled out, provided the system assures water tightness.

Appropriately coated carbon steels or austenitic type stainless steels must be chosen as suitable materials to fasten panels. Pay particular attention to the compatibility of the steel and aluminium materials in order to prevent the formation of galvanic currents.

Fastening methods

Fastening varies based on the design to be constructed and on the panel application system at the construction site.

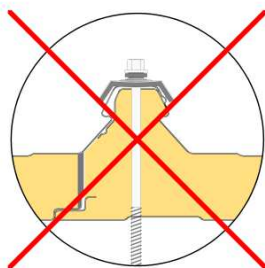

A

Incorrect tightening due to high torque applied to the screw with marked deformations of the sheet. **In this situation the optimal closing of the interlocking is no longer guaranteed, therefore, the aesthetic functionality of the product remains compromised.**

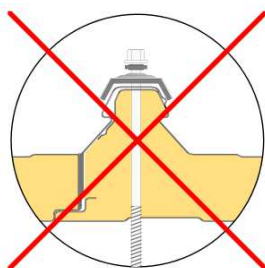

B

Incorrect tightening due to the torque applied to the screw being insufficient to ensure correct fastening of the panel to the structure.

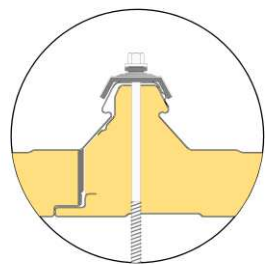

C

Correct tightening obtained by applying sufficient torque to the screw to ensure fastening of the panel to the structure.

Screw length

The proper screw length depends on panel thickness and on the type of support (steel, wood); when installing roof panels, caps must be used.

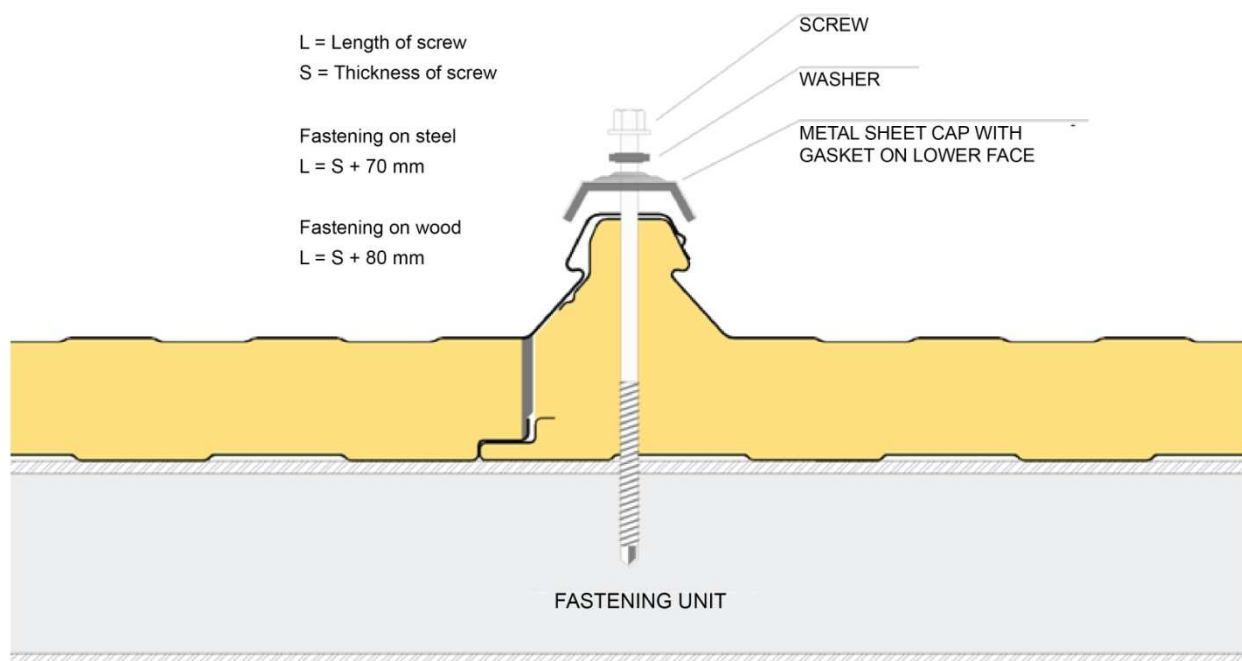

Roof panel fastening

The panels must be installed opposite the direction of the prevailing winds, frequently checking to make sure they are parallel and aligned. The holes must have a smaller diameter than the fastening elements. The number of fastenings depends on the local climatic zone. The normal fastening density entails one on every other rib on central beams and one on every rib on terminal beams.

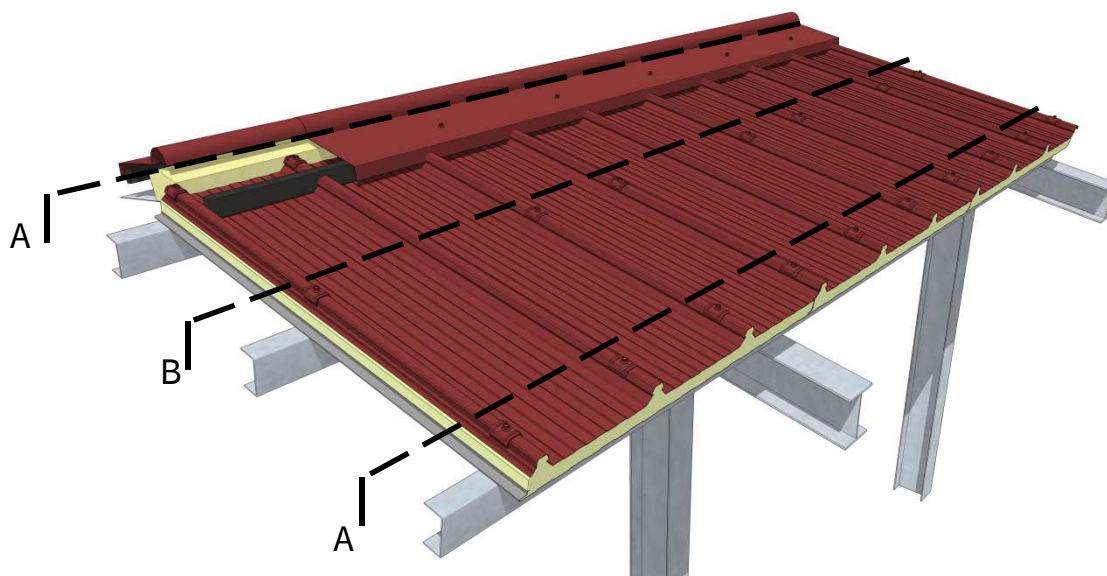

A: terminal beams

B: central beams

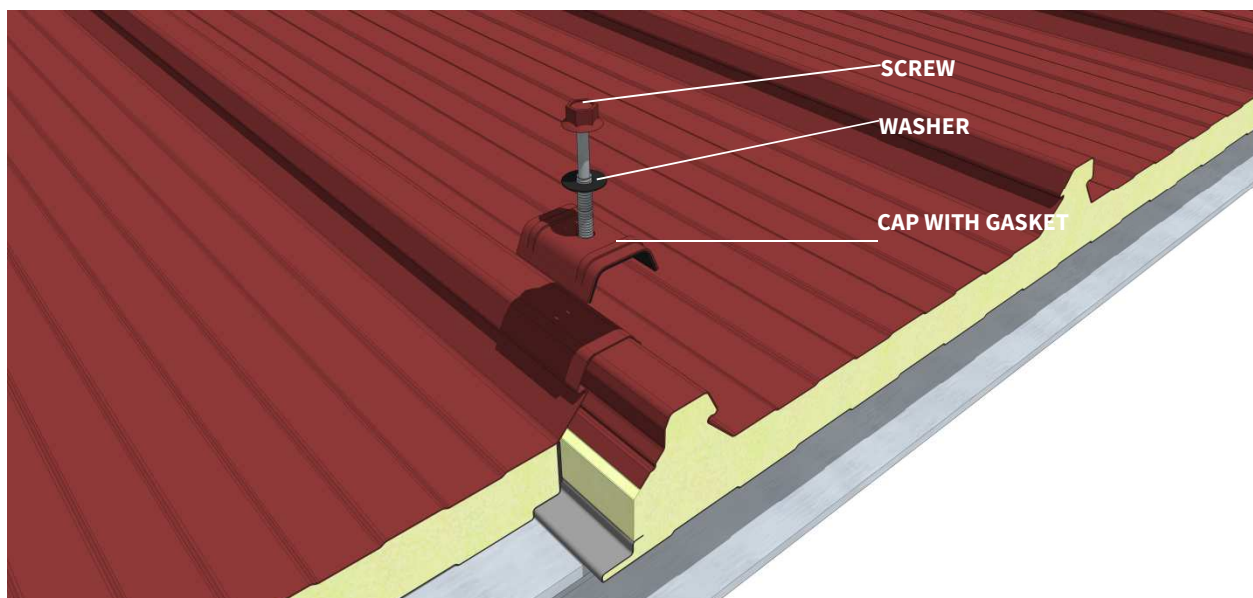

Assembly sequence

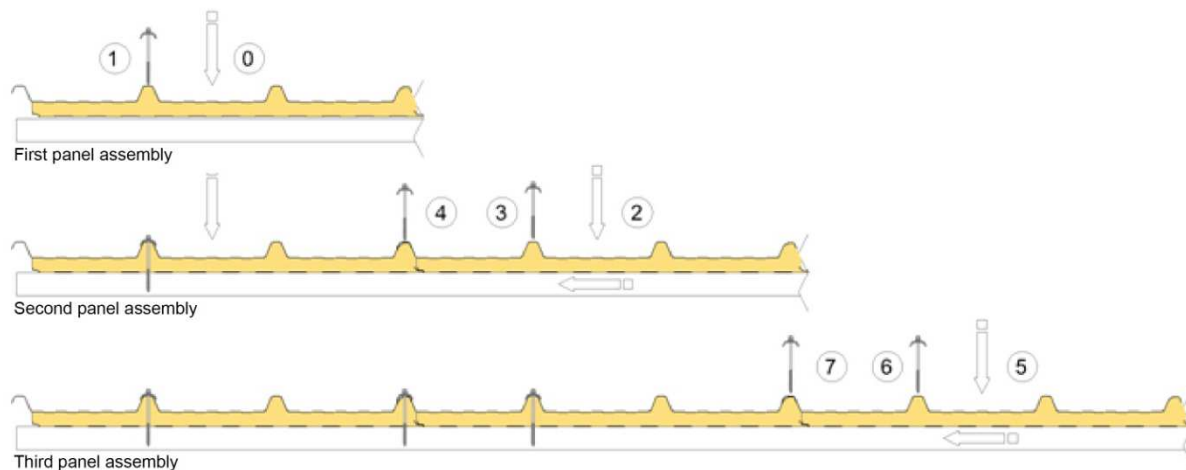

- 1) Install the first panel.
- 2) Fasten the screw on one of the two central ribs.
- 3) Install the second panel and couple it to the already installed first panel.
- 4) Fasten the screw on the central rib of the second panel, ensuring to exert slight pressure in order to assure the panels are coupled during this step.
- 5) Fasten the screw on the overlapping rib.

Proposed Isopan fastening system

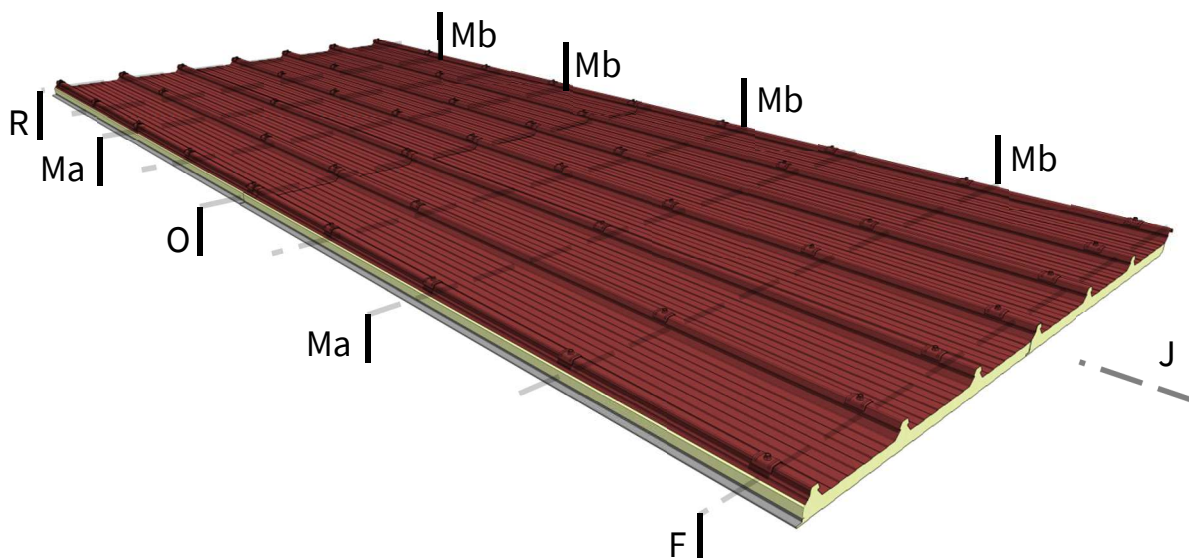

- R: terminal support (ridge)
- F: terminal support (gutter)
- Ma-Mb: intermediate supports
- O: support at the head junction
- J: longitudinal joint

Isopan detail of the head junction

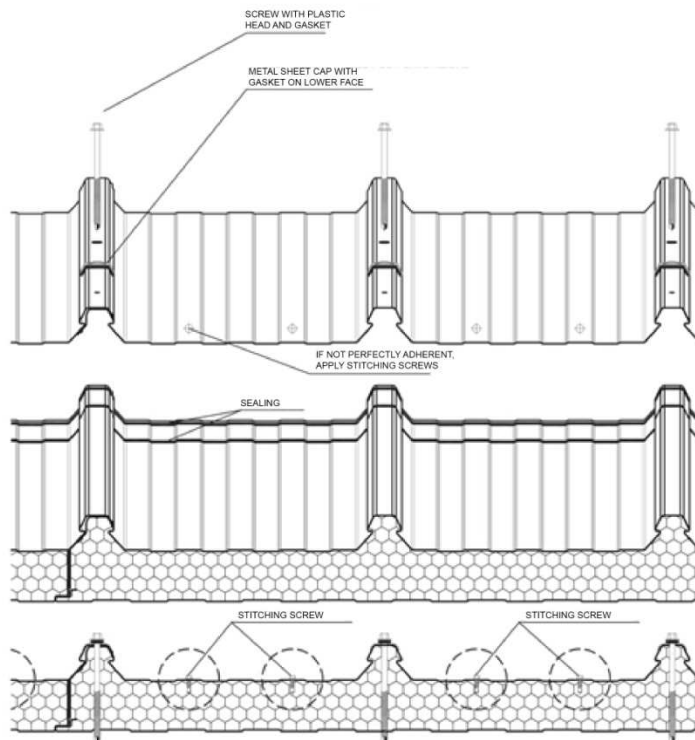
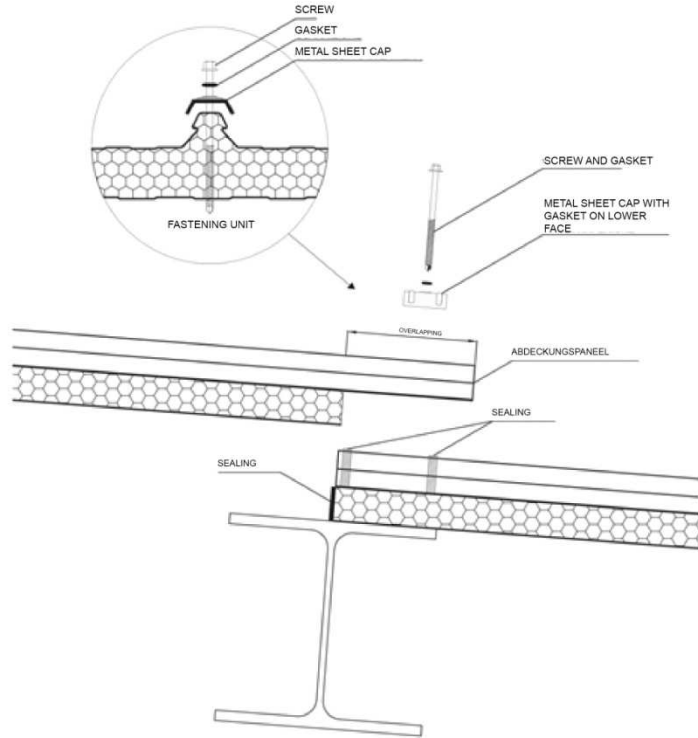

Isopan convention called overlapping

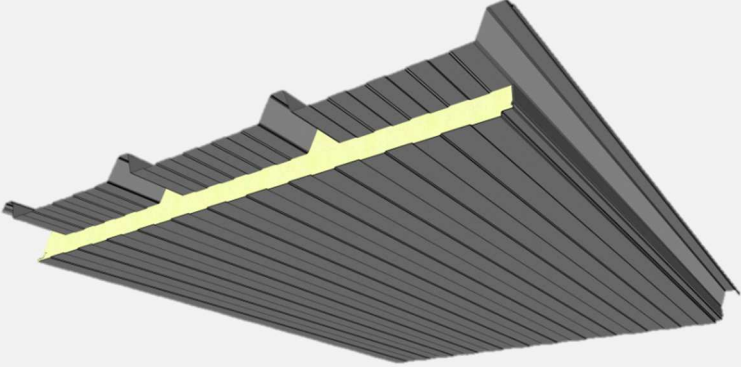
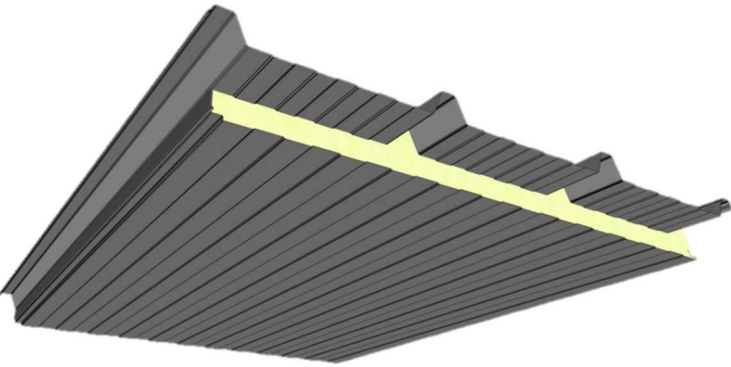
<p>Right overlap</p>	 <p>* the picture is indicative, it shows type Isocop 4.</p>
<p>Left overlap</p>	 <p>* the picture is indicative, it shows type Isocop 4.</p>

Note: should the panels not fit perfectly between the ribs, Isopan recommends applying stitching screws.

MULTIFUNCTION APPLICATIONS

Use for roofing

The ISOCOP MULTIFUNZIONE panel may be used on roofs to hook photovoltaic modules. A suitable hooking accessory has been designed for this application, to install the modules quickly and conveniently.

The hooking system is snapped onto the rib. To better tighten the system to the rib, a screw with adjusting nut must be put in.

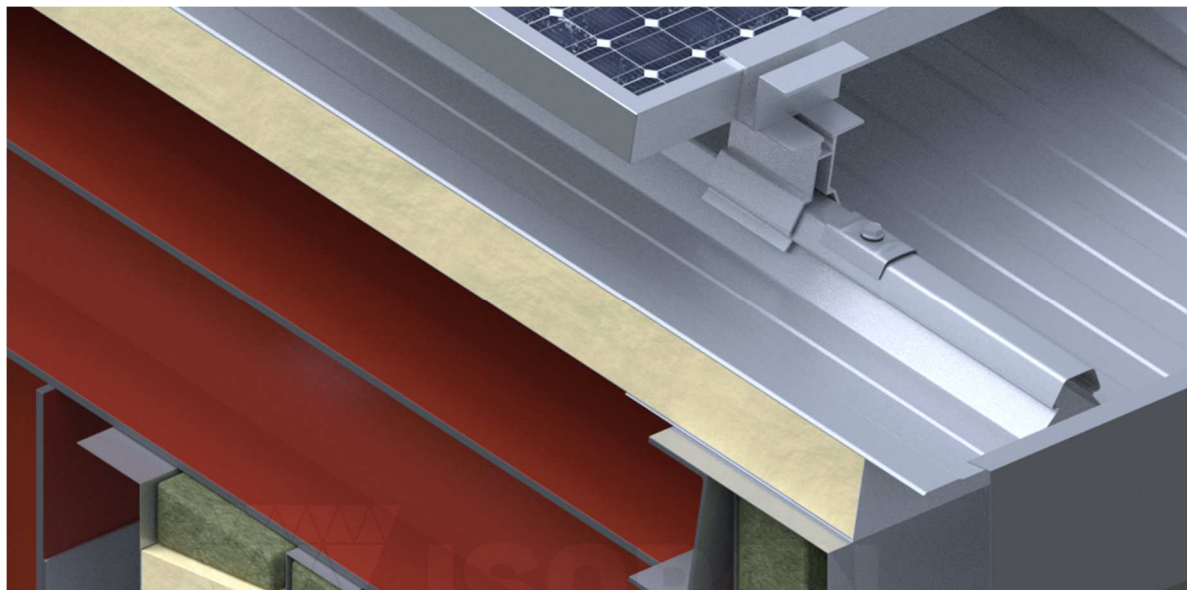

False ceiling application

The ISOCOP MULTIFUNZIONE panel may also be used to make false ceilings, installing the panel to the intrados of the ceiling with the ribs facing down and by using the same accessory used for hooking the photovoltaic panels.

The substructure supporting the false ceiling may be installed on the snap hooks fastened to the ribs.



Use on walls

The ISOCOP MULTIFUNZIONE panel may be used on the wall using the hooking bracket in the same way as it is mounted on roof and false ceiling, to make ventilated façades or to fasten other finishing layers of the wall, whether internal or external.

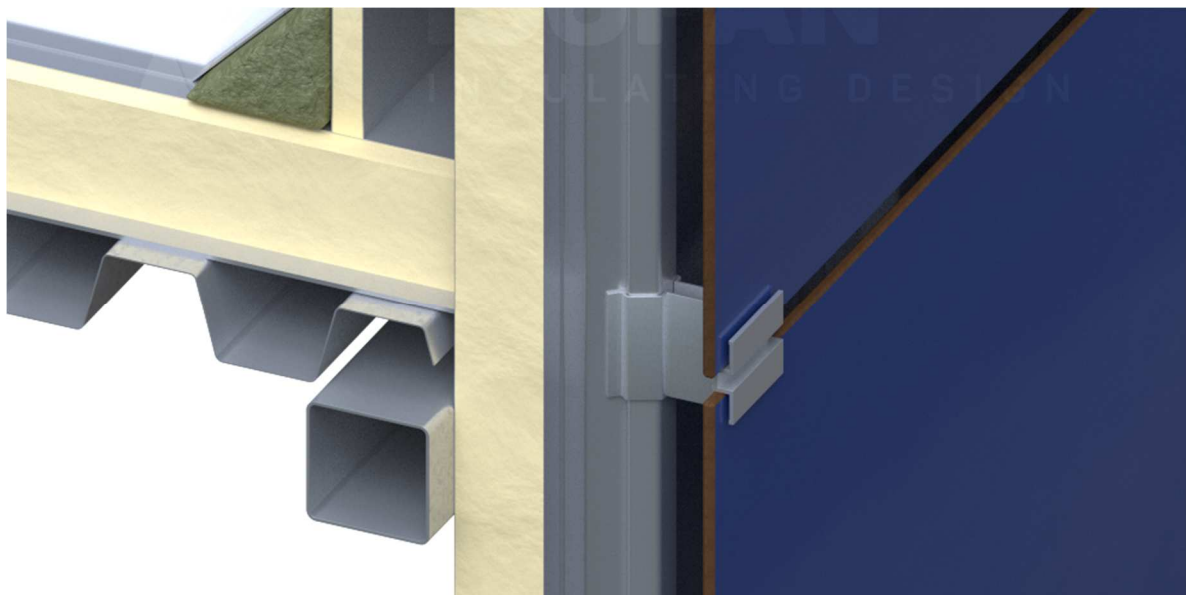

ASSEMBLY INSTRUCTIONS

The correct sequence of assembly operations is the following:

Preliminary operations

- Verify that the supports are properly aligned.
- Pay particular attention to the contact points between the supports and the panel support plates to avoid phenomena linked to electrochemical corrosion if incompatible metals are coupled. For this purpose, elastomer or expanded resin strips may be applied as separators.
- Ensure that the site area has appropriate storage and handling capacity in order to prevent material damage.
- Use suitable tools (toothed circular saw, jigsaw, shears, nibbler) for on-site cutting operations. The use of equipment that produces metallic sparks (e.g. abrasive discs, disc cutter) is absolutely not recommended.
- Use suitable handling systems, particularly for long or heavy panels, in order to prevent safety risks on site and damages to the product.

Using acetic silicones is prohibited as they tend to attack the pre-painted galvanised face and form incipient oxidation. It is best to use single component sealant silicones with neutral curing that tend to harden due to the air humidity and, being free of solvents, do not attack the paint.

Assembly

- Install gutters and any sub-ridges and connection ridge caps.
- Remove the protective film from the panels, if any.
- Installing the panels starting from the gutter and from an end side of the building, taking care to correctly overlap and align the elements and check for perfect orthogonality to the underlying structure.
- Systematically fasten the elements after ensuring they match correctly. All the residual materials must be quickly removed, with special attention to metallic residues.
- Install the subsequent row of elements overlapping the gutter row (when there are roof pitches in two or more elements). The insulating core in the overlapping area must first be removed.
- Fasten the elements on all the ribs on the ridge, gutter, valley and head overlap lines.
- Install finishing elements (ridges, ridge caps, and tinwork in general) and any related insulating elements.
- General check and cleaning of the roof, with special focus on metal scraps, fasteners and connections with the door and window frames. After completing panel and tinwork element assembly, make sure no foreign material or processing scraps are left on the roof, as these may trigger corrosion phenomena, prevent proper rainwater draining or create a build-up of aggressive, undesired substances.

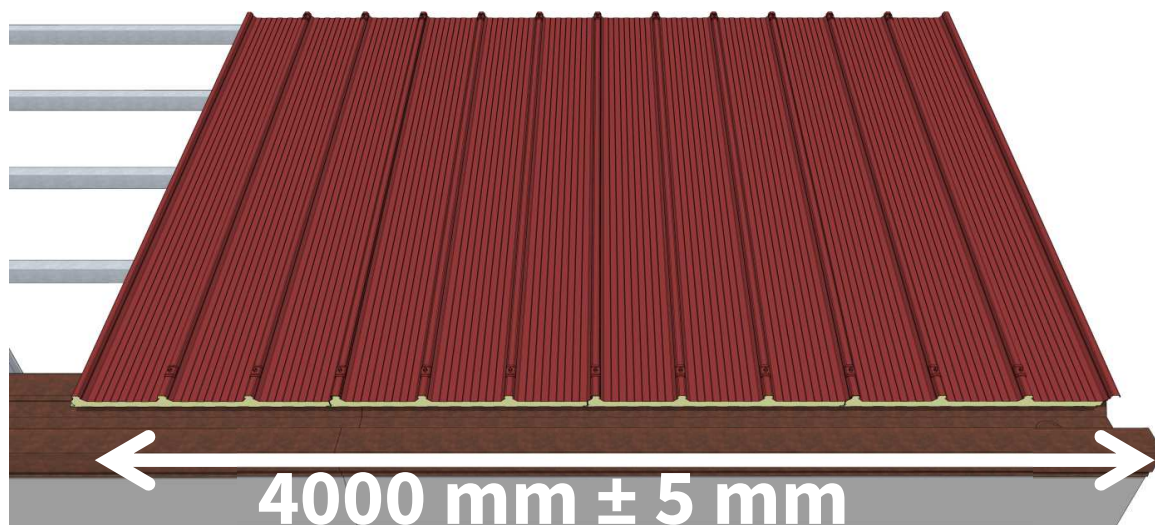

Note: take care to properly place the panels during the assembly step (4 panels = 4000 mm ± 5 mm) in order to prevent problems during the next ridge installation step, as shown in the figure.

PACKAGE COMPOSITION

The panels are normally supplied packaged and wrapped with extensible polyethylene film; the standard composition of the package is as shown below:

Panel thickness (mm)	30	40	50	60	80	100	120
No. of panels per package	14	12	10	8	6	6	4

Package compositions and types of packaging other than standard must be explicitly requested when ordering.

TRANSPORT AND STORAGE

Lorry loading

- The packages of panels are loaded on lorries, usually two in width and three in height. The packages include polystyrene spacers at the base, which are thick enough to allow for the lifting straps.
- The goods are arranged on the vehicles so as to ensure safe transportation and integrity of the material, in accordance with the requirements of the carrier, who is solely responsible for load integrity. Pay special attention to ensure the weight bearing on the bottom package, as well as the pressure exerted in the tying points, do not cause damage and the straps do not distort the shape of the product in any way.
- Isopan assumes no liability for loading lorries that are already partially occupied by other materials, or that do not have a suitable loading floor.

Customers who will pick up the material must instruct the drivers accordingly.

Lorry unloading with crane

- Use any type of crane equipped with spreader beam and equipped straps. Isopan can advise customers on the choice of spreader beams and straps. By using correct lifting systems, the panels will not be damaged.
- Never use chains or metal cables for lifting under any circumstances. As a general rule, sling the packages leaving about 1/4 of their length protruding from each end.

Lorry unloading with forklifts

- If the lorries are unloaded using a forklift, the length of the packages and their possible bending should be taken into account in order to prevent damages to the bottom of the package.
- The forks must be wide and long enough in order not to damage the product. When possible, protective material against surface abrasion and scratches should be applied between the fork and the package.

Indoor storage (Annex A)

- The materials must be stored in ventilated indoor facilities that are free of dust and humidity and not subject to temperature changes.
- Moisture that can penetrate (rain) or form (condensation) between two panels can damage the facings since it is particularly aggressive on metals and facings, with subsequent oxidation.
- Pre-painted facings may be more exposed to the negative consequences of combined heat/humidity conditions.

Outdoor storage (Annex A)

- If the packages and accessories are stored outdoors, the surface must absolutely be inclined longitudinally to prevent moisture from accumulating and to allow water run-off and natural air circulation.
- If storage is not shortly followed by pick-up for installation, it is advisable to cover the packages with a protective tarp, assuring impermeability as well as adequate ventilation to prevent condensate from accumulating and puddles of water from forming.

Storage terms (Annex A)

- Based on experience, in order to maintain original product performance, continuous indoor storage in closed and ventilated facilities should not exceed six months, while outdoor storage should never exceed sixty days from the date of production. These terms refer to the properly stored product, as instructed in the "storage" chapter in Annex A. However, the materials must always be protected against direct sunlight, as it may cause alterations.
- In case of transport in containers, the products must be removed from the containers as soon as possible and, however, no later than 15 days from the loading date, to prevent deterioration of the metal supports and organic coatings (e.g. blistering). Moisture inside the container must absolutely be avoided. Upon customer request, Isopan can provide special packages that are more suitable for transport in containers.

PACKAGING

Isopan suggests carefully choosing the type of packaging depending on destination, type of transport, conditions and length of storage.

To choose the correct type of packaging, please refer to the "**Packaging and Services**" document on www.isopan.com.

DURABILITY

Product durability depends on the intrinsic features of the panel used in relation with its final use. The panel, including the features of the metal supports, must be chosen after the roof has been properly designed.

In this regard we recommend, if necessary, using the Isopan documentation, also available on the web (www.isopan.com), and/or the reference standards.

We recommend, especially for roof panels with metal facings in pre-painted galvanised steel, checking the roof pitch slope and other construction details in order to promote normal water drainage and prevent aggressive materials from accumulating, which would lead to premature oxidation.

In the event of roof pitches with longitudinal overlapping (panel overlap), we recommend paying special attention during installation to seal the sheets in order to prevent leaks or stagnation on the end part of the panel.

We recommend using accessories like ridge tinwork, caps and gaskets supplied by Isopan, as they are appropriately designed for the specific use of the manufactured products.

MAINTENANCE

All types of facings, including those made with metal sandwich panels, require maintenance.

The type and frequency of maintenance activities depend on the product used for the external facing (steel, aluminium); in any case, we recommend periodically inspecting the building (at least once a year), in order to assess its conditions.

In order to maintain the aesthetic and physical properties of the elements and to extend the efficiency of the protective facing, it is also recommended to regularly clean the roof, paying special attention to the areas that could facilitate rain water stagnation, where substances that are harmful to the durability of the metal support may be concentrated.

If you notice any problems following an on-site inspection, you must react immediately in order to restore the initial general conditions (e.g. restoring the paint where there are local abrasions or scratches).

Upon customer request, Isopan can provide useful information to solve some problems related to this topic.

SAFETY AND DISPOSAL

Pursuant to Directive 68/548/EEC the sandwich panel does not require labelling. To meet customer requirements, Isopan has drawn-up a "Technical details for safety" document, to be referenced for any kind of information related to safety.

Caution: all information contained in the product data sheets must be validated by a qualified technician according to the laws in force in the country where the panels are installed.

Technical specifications and features are not binding. Isopan reserves the right to make changes without prior notice; the latest documentation is available on our website www.isopan.com. For whatever is not explicitly specified herein, please refer to the "General conditions of sale of the corrugated metal sheets, insulated metal panels and accessories". All the products that fall under the EN 14509 standard field of application are CE marked.

This document and all the elements it contains are the exclusive property of Isopan. Reproduction, even in part, of the texts and any images contained herein without the author's written authorisation is forbidden.

Copyright © 2015 – ISOPAN S.p.A.

Annex A

LORRY UNLOADING WITH CRANE

For lifting, the packages must always be sling in at least two points. The distance between them must be no less than half the length of the packages.

Lifting should be possibly carried out using synthetic fibre straps (Nylon) no thinner than 10 cm, so that the load is distributed on the strap and does not cause distortion.

(see Figure 1)

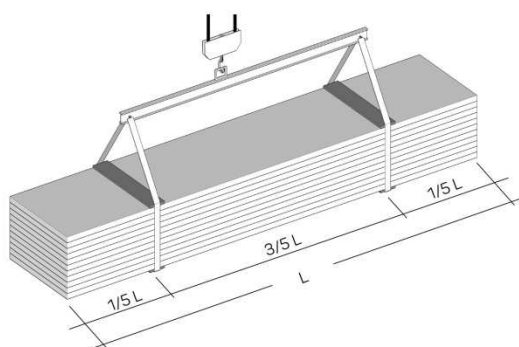

Figure 1

Suitable spacers must be placed under and above the package, made of sturdy solid wood or plastic elements to avoid direct contact of the strap with the package.

These spacers must be at least 4 cm longer than the width of the package and be at least as wide as the strap.

Make sure that the straps and supports cannot move during lifting and that manoeuvres are performed cautiously.

LORRY UNLOADING WITH FORKLIFTS

If the lorries are unloaded with a forklift, take into account the length of the packages and their possible bending in order to avoid damaging the bottom of the package and/or to the extreme failure limit of the panels.

We recommend using forklifts that are suitable for handling panels and similar products.

STORAGE

The packages must always be kept off the ground both in the warehouse and, more so, at the construction site. They must have plastic foam supports with flat surfaces longer than the width of the panels and at a distance adequate to the features of the product.

The packages should preferably be stored in dry facilities to prevent stagnation of condensation water on inner, less ventilated, elements, which is particularly aggressive on metals, resulting in the formation of oxidation.

The panels must be stored in dry ventilated facilities; should this not be possible, open the packages and ventilate the panels (spacing them from one other). If the panels remain packaged outdoors, the galvanised facing may oxidise (white rust) even after a few days, due to electrolytic corrosion.

The panels must be stored to facilitate water run-off, especially when it is necessary to temporarily store them outside (see Figure 2).

If storage is not shortly followed by pick-up for installation, it is advisable to cover the packages with protective tarps.

To maintain original product performance, continuous indoor storage in ventilated facilities should not exceed six months, while outdoor storage should never exceed 60 days.

Packages stored at a height must always be properly bound to the structure.

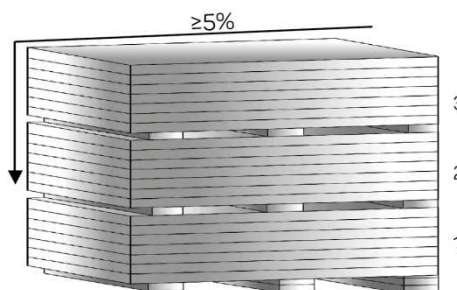

Figure 2

PRE-PAINTED FACES



In case of prolonged storage, the pre-painted products must be stored indoors or under a canopy. There is the risk that stagnant humidity may attack the paint layer, causing it to detach from the galvanised support. It is not advisable to let more than two weeks elapse from when the products were stored at the site.

In case of container transport, the products must be removed from the container within 15 days from the loading date in order to prevent the metal supports from deteriorating.

PANEL HANDLING

The panels must be handled using adequate protection equipment (safety shoes, gloves, overalls, etc.) in compliance with current regulations.

The individual element must always be manually handled by lifting the element without dragging it on the ground and turning it sideways beside the package; it must be transported by at least two people according to the length, keeping the element on its side. (see Figure 3)

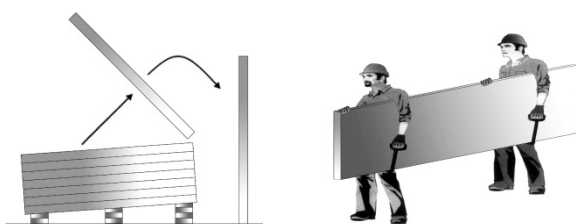

Figure 3
 Handling equipment as well as gloves must be clean and such as not to damage the items.

INSTALLATION

The panel installation personnel must be qualified and know the correct technique to perform the work in a workmanlike manner. If required, the seller can provide appropriate guidance and instructions.

The installation personnel must be equipped with footwear with soles that do not damage the external surface of the panel.

On-site cutting operations must be done with suitable tools (jigsaw, shears, nibbler, etc.).

We do not recommend using tools with abrasive discs.

To fasten the panels, it is advisable to use devices that can be provided by the seller.

Tighten the screws using a screwdriver with torque limitation.

For roofs with pitch elements without intermediate joints (overlaps), the slope should usually be no less than 7%. For slopes below that, the seller's requirements must be implemented.

In case of head overlaps, the slope should take into account the type of joint and material used, as well as the specific environmental conditions.

During panel assembly and, in particular, in roofs, it is necessary to immediately remove all residual materials paying special attention to metal ones that may cause early deterioration of the metal faces by oxidising.

PROTECTIVE FILM

The pre-painted metal facings are supplied upon request with adhesive polyethylene protective film that prevents damage to the paint layer.

The protective film covering the pre-painted panels must be completely removed during assembly or, in any case, within 60 days from material preparation.

It is also recommended not to expose the panels covered with protective film to direct sunlight.

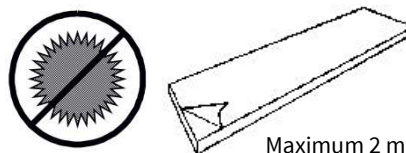

For the panels expressly requested without protective film, special care is required during handling on site and installation.

MAINTENANCE

The main routine maintenance operation is cleaning the panels. The panel surfaces that, following visual inspection, are found to be dirty or oxidised can be washed with soap and water using a soft brush. The cleaning water pressure can be applied up to 50 bar, but the jet must not be too close or perpendicular to the surfaces. Near the joints the water must be sprayed at a sufficient angle not to undermine their tightness.

YEARLY CHECKS OF THE ISOPAN PANELS	
WHAT TO INSPECT	CORRECTIVE ACTIONS
Conditions of the pre-painted surfaces (cracks and colour unevenness)	Assess the condition of the surfaces Repaint where possible
Scratches and dents	Repaint and repair dents
Fastening screws	Remove a screw and check if oxidised Tighten the screws where necessary
Angle parts of cut	Check the state of oxidation Clean and repaint

These provisions are taken from the General Conditions of Sale.

Annex B

SUCTION CUP LIFTERS

In the event the panels are handled using **suction cup lifters** the operations must be carried out ensuring the panel is not deformed. The action of the suction cup on the sheet during lifting must be **adequately redistributed** taking into account the panel's **length** and **weight**.

To prevent excessive force by the suction cups from causing detachment of the sheet from the insulating core, Isopan recommends complying with the following restrictions:

Polyurethane panels:

Minimum Total Surface of Suction Cups for Polyurethane Panel with Steel face 0.4 / 0.4												
Panel Length	Panel thickness [mm]											
	25	30	35	40	50	60	80	100	120	150	180	200
2000 mm	340 cm2	350 cm2	350 cm2	360 cm2	380 cm2	390 cm2	430 cm2	460 cm2	490 cm2	540 cm2	590 cm2	620 cm2
3500 mm	590 cm2	600 cm2	620 cm2	630 cm2	660 cm2	690 cm2	740 cm2	800 cm2	850 cm2	940 cm2	1,020 cm2	1,080 cm2
5000 mm	840 cm2	860 cm2	880 cm2	900 cm2	940 cm2	980 cm2	1,060 cm2	1,140 cm2	1,220 cm2	1,340 cm2	1,460 cm2	1,540 cm2
6500 mm	1,090 cm2	1,120 cm2	1,140 cm2	1,170 cm2	1,220 cm2	1,270 cm2	1,380 cm2	1,480 cm2	1,580 cm2	1,740 cm2	1,900 cm2	2,000 cm2
8000 mm	1,340 cm2	1,370 cm2	1,400 cm2	1,440 cm2	1,500 cm2	1,560 cm2	1,690 cm2	1,820 cm2	1,950 cm2	2,140 cm2	2,330 cm2	2,460 cm2
10000 mm	1,670 cm2	1,710 cm2	1,750 cm2	1,790 cm2	1,870 cm2	1,950 cm2	2,110 cm2	2,270 cm2	2,430 cm2	2,670 cm2	2,910 cm2	3,070 cm2
13000 mm	2,170 cm2	2,230 cm2	2,280 cm2	2,330 cm2	2,430 cm2	2,540 cm2	2,750 cm2	2,950 cm2	3,160 cm2	3,470 cm2	3,790 cm2	3,990 cm2

Minimum Total Surface of Suction Cups for Polyurethane Panel with Steel face 0.6 / 0.6

Panel Length	Panel thickness [mm]											
	25	30	35	40	50	60	80	100	120	150	180	200
2000 mm	490 cm2	490 cm2	500 cm2	510 cm2	530 cm2	540 cm2	570 cm2	610 cm2	640 cm2	690 cm2	730 cm2	770 cm2
3500 mm	850 cm2	860 cm2	870 cm2	890 cm2	920 cm2	940 cm2	1,000 cm2	1,060 cm2	1,110 cm2	1,200 cm2	1,280 cm2	1,340 cm2
5000 mm	1,210 cm2	1,230 cm2	1,250 cm2	1,270 cm2	1,310 cm2	1,350 cm2	1,430 cm2	1,510 cm2	1,590 cm2	1,710 cm2	1,830 cm2	1,910 cm2
6500 mm	1,570 cm2	1,590 cm2	1,620 cm2	1,640 cm2	1,700 cm2	1,750 cm2	1,850 cm2	1,960 cm2	2,060 cm2	2,220 cm2	2,370 cm2	2,480 cm2
8000 mm	1,930 cm2	1,960 cm2	1,990 cm2	2,020 cm2	2,090 cm2	2,150 cm2	2,280 cm2	2,410 cm2	2,530 cm2	2,730 cm2	2,920 cm2	3,050 cm2
10000 mm	2,410 cm2	2,450 cm2	2,490 cm2	2,530 cm2	2,610 cm2	2,690 cm2	2,850 cm2	3,010 cm2	3,170 cm2	3,410 cm2	3,650 cm2	3,810 cm2
13000 mm	3,130 cm2	3,180 cm2	3,230 cm2	3,280 cm2	3,390 cm2	3,490 cm2	3,700 cm2	3,910 cm2	4,120 cm2	4,430 cm2	4,740 cm2	4,950 cm2

Minimum Total Surface of Suction Cups for Polyurethane Panel with Steel face 0.8 / 0.8

Panel Length	Panel thickness [mm]											
	25	30	35	40	50	60	80	100	120	150	180	200
2000 mm	630 cm2	640 cm2	650 cm2	660 cm2	670 cm2	690 cm2	720 cm2	750 cm2	780 cm2	830 cm2	880 cm2	910 cm2
3500 mm	1,100 cm2	1,120 cm2	1,130 cm2	1,140 cm2	1,170 cm2	1,200 cm2	1,260 cm2	1,310 cm2	1,370 cm2	1,450 cm2	1,540 cm2	1,590 cm2
5000 mm	1,570 cm2	1,590 cm2	1,610 cm2	1,630 cm2	1,670 cm2	1,710 cm2	1,790 cm2	1,870 cm2	1,950 cm2	2,070 cm2	2,190 cm2	2,270 cm2
6500 mm	2,040 cm2	2,070 cm2	2,100 cm2	2,120 cm2	2,170 cm2	2,230 cm2	2,330 cm2	2,430 cm2	2,540 cm2	2,690 cm2	2,850 cm2	2,950 cm2
8000 mm	2,510 cm2	2,550 cm2	2,580 cm2	2,610 cm2	2,670 cm2	2,740 cm2	2,870 cm2	2,990 cm2	3,120 cm2	3,310 cm2	3,510 cm2	3,630 cm2
10000 mm	3,140 cm2	3,180 cm2	3,220 cm2	3,260 cm2	3,340 cm2	3,420 cm2	3,580 cm2	3,740 cm2	3,900 cm2	4,140 cm2	4,380 cm2	4,540 cm2
13000 mm	4,080 cm2	4,130 cm2	4,190 cm2	4,240 cm2	4,340 cm2	4,450 cm2	4,650 cm2	4,860 cm2	5,070 cm2	5,380 cm2	5,690 cm2	5,900 cm2

Mineral wool panels:

Minimum Total Surface of Suction Cups for Mineral Wool Panel with Steel face 0.5 / 0.5							
Panel Length	Panel thickness [mm]						
	50	60	80	100	120	150	200
2000 mm	470 cm ²	490 cm ²	510 cm ²	530 cm ²	570 cm ²	610 cm ²	690 cm ²
3500 mm	820 cm ²	860 cm ²	890 cm ²	930 cm ²	1,000 cm ²	1,070 cm ²	1,210 cm ²
5000 mm	1,170 cm ²	1,220 cm ²	1,270 cm ²	1,320 cm ²	1,420 cm ²	1,520 cm ²	1,720 cm ²
6500 mm	1,520 cm ²	1,590 cm ²	1,650 cm ²	1,720 cm ²	1,850 cm ²	1,980 cm ²	2,240 cm ²
8000 mm	1,870 cm ²	1,950 cm ²	2,030 cm ²	2,110 cm ²	2,270 cm ²	2,430 cm ²	2,750 cm ²
10000 mm	2,340 cm ²	2,440 cm ²	2,540 cm ²	2,640 cm ²	2,840 cm ²	3,040 cm ²	3,440 cm ²
13000 mm	3,040 cm ²	3,170 cm ²	3,300 cm ²	3,430 cm ²	3,690 cm ²	3,950 cm ²	4,470 cm ²

Minimum Total Surface of Suction Cups for Mineral Wool Panel with Steel face 0.8 / 0.8							
Panel Length	Panel thickness [mm]						
	50	60	80	100	120	150	200
2000 mm	690 cm ²	710 cm ²	730 cm ²	750 cm ²	790 cm ²	830 cm ²	910 cm ²
3500 mm	1,210 cm ²	1,240 cm ²	1,280 cm ²	1,310 cm ²	1,380 cm ²	1,450 cm ²	1,590 cm ²
5000 mm	1,720 cm ²	1,770 cm ²	1,820 cm ²	1,870 cm ²	1,970 cm ²	2,070 cm ²	2,270 cm ²
6500 mm	2,240 cm ²	2,300 cm ²	2,370 cm ²	2,430 cm ²	2,560 cm ²	2,690 cm ²	2,950 cm ²
8000 mm	2,750 cm ²	2,830 cm ²	2,910 cm ²	2,990 cm ²	3,150 cm ²	3,310 cm ²	3,630 cm ²
10000 mm	3,440 cm ²	3,540 cm ²	3,640 cm ²	3,740 cm ²	3,940 cm ²	4,140 cm ²	4,540 cm ²
13000 mm	4,470 cm ²	4,600 cm ²	4,730 cm ²	4,860 cm ²	5,120 cm ²	5,380 cm ²	5,900 cm ²

Note: For thicknesses not listed in the table, perform linear interpolation.

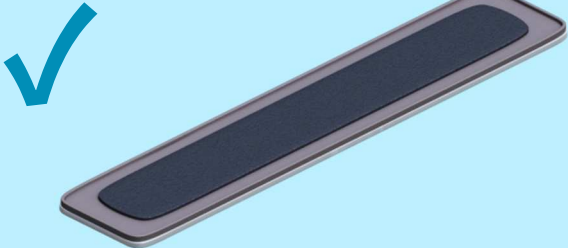
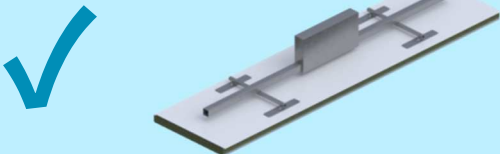
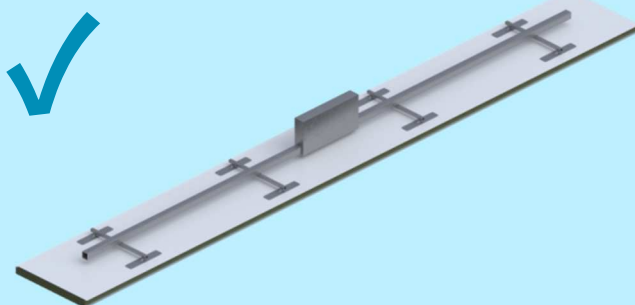
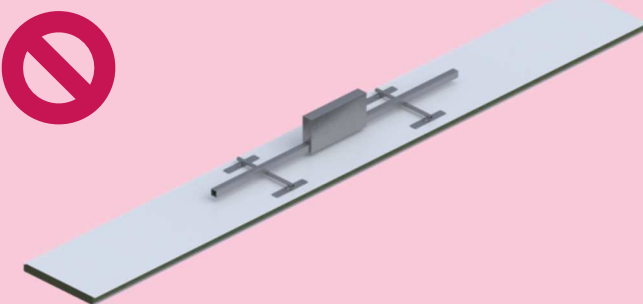
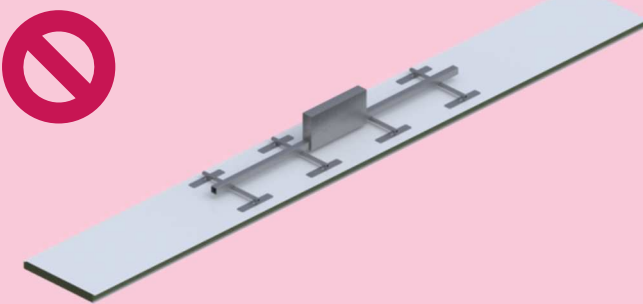
<p>TO ASSURE SHEET PLANARITY DURING SUCTION, A SUITABLE STIFFENING PAD MUST BE INSERTED IN THE SUCTION CUP</p>	
<p>AT LEAST 4 SUCTION CUPS EQUALLY DISTRIBUTED FOR PANEL LENGTHS LESS THAN 6 m</p>	
<p>AT LEAST 8 SUCTION CUPS EQUALLY DISTRIBUTED FOR PANEL LENGTHS EXCEEDING 6 m</p>	
<p>INSUFFICIENT NUMBER OF SUCTION CUPS</p> <p>SUCTION CUPS NOT EQUALLY DISTRIBUTED</p>	
	

Annex C

BUILDING DETAILS

- SPV 23 – Isocop Multifunzione and ventilated façade system [Base]
- SPV 24 – Isocop Multifunzione and ventilated façade system [Roof]
- SCV 27 – Isocop Multifunzione and false ceiling system
- RPCV 06 – *Cantilever roof wall connection with gutter*
- RPCV 13 – *Flat roof wall connection*
- RPCV 14 – *Roof wall connection with insulated gutter with parapet*
- RPCV 03 – *Roof wall connection with gutter*
- RPCV 04 – *Roof wall connection with single roof pitch ridge*
- RPCV 01 – *Roof wall connection with insulated gutter*
- SCV 01 – *Dual pitch roof single piece ridge*
- SCV 02 – *Dual pitch roof hinged ridge*
- SCV 03 – *Flat roof wall connection*
- SCV 04 – *Inclined roof wall connection*
- SCV 05 – *Roof connection on valley gutter*
- SCV 24 – *Overlap fastening*
- SCV 25 – *Stitching screw positioning*

ISOCOP MULTIFUNZIONE AND VENTILATED FAÇADE SYSTEM [BASE]

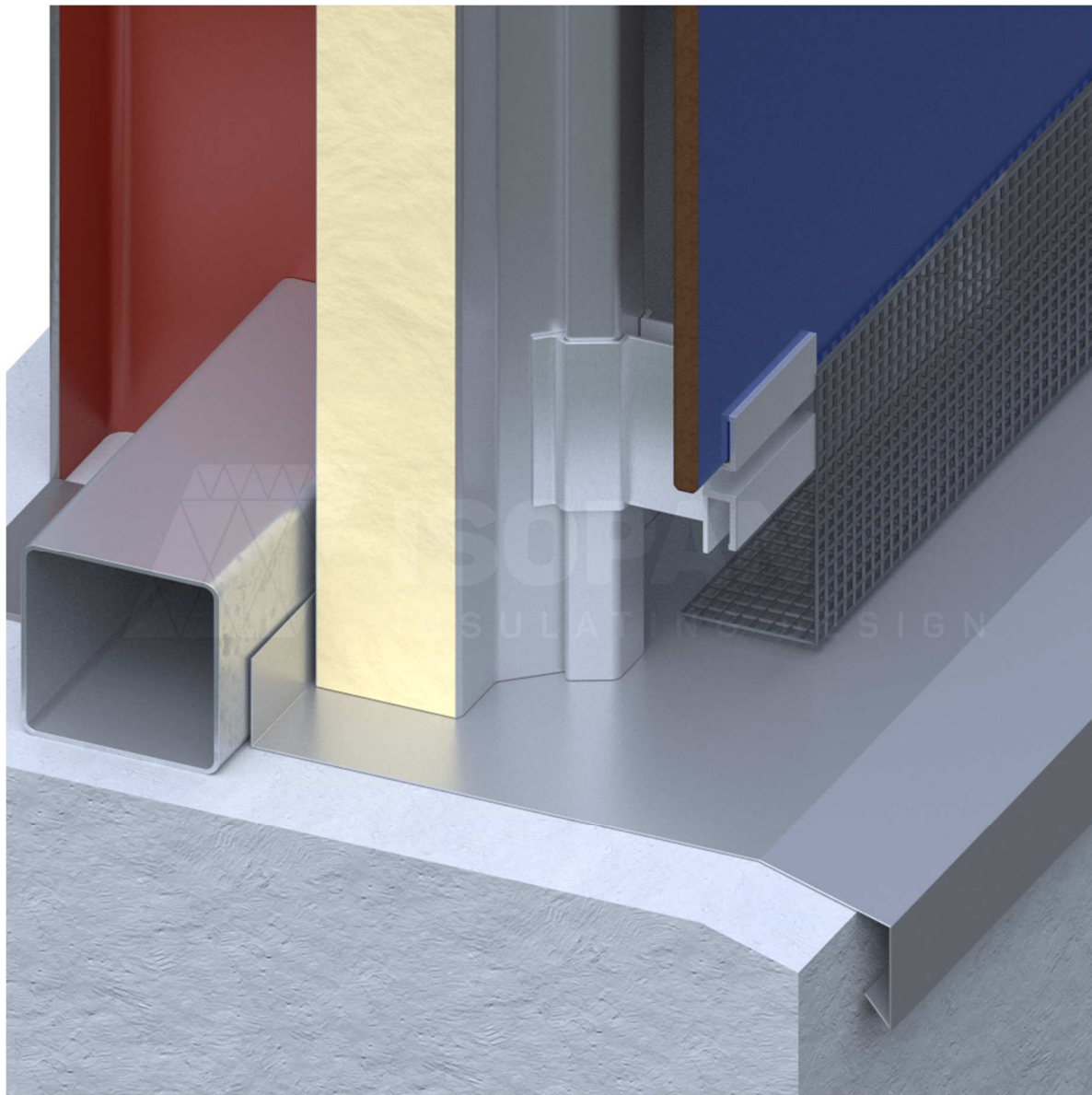

Isocop Multifunzione and ventilated façade system [Base]

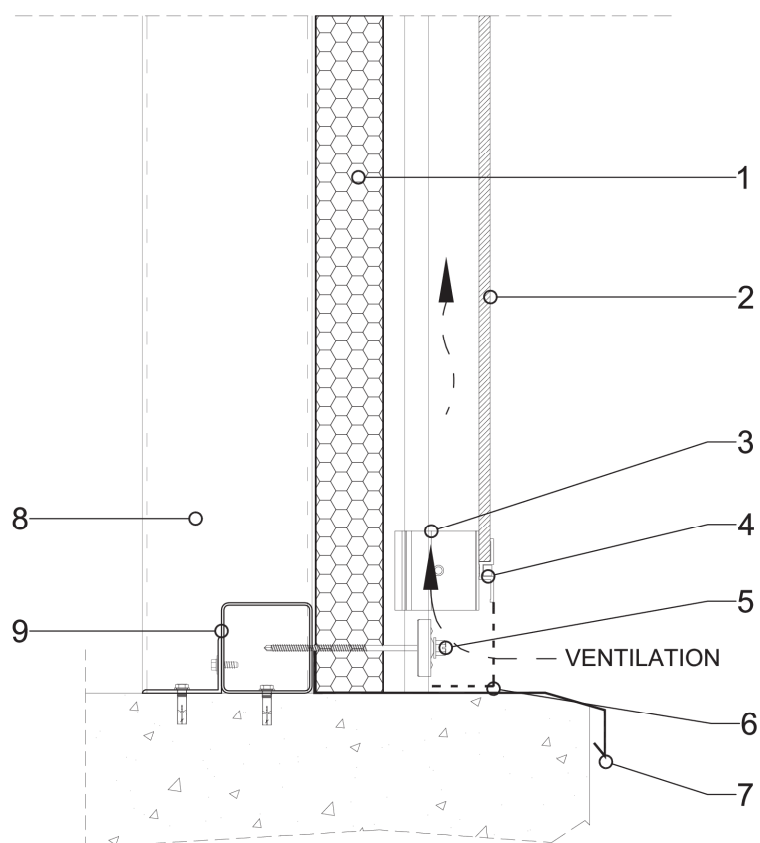

The designer is responsible for assessing the need to insert additional gasket and/or closing elements, even when not indicated in the drawing details.

Key

1	ISOCOP MULTIFUNZIONE panel
2	Façade panel
3	Bracket for ISOCOP MULTIFUNZIONE
4	Retainer clamp for façade panel
5	Fastening unit
6	Mineral wool insulating material
7	Water protective tinwork
8	Load-bearing metal structure
9	Secondary load-bearing metal structure

ATTENTION: the proposed solution does not represent a project, and must be examined and assessed prior by the designer or Clerk of Works. The property rights of this document belong exclusively to ISOPAN S.p.a. Reproduction even in part without prior written authorisation by the author is forbidden. To choose the type of fastening, please refer to the screw type choice sheet; To choose the screw length, please refer to the data sheet for the correct screw length.

ISOCOP MULTIFUNZIONE AND VENTILATED FAÇADE SYSTEM [ROOF]

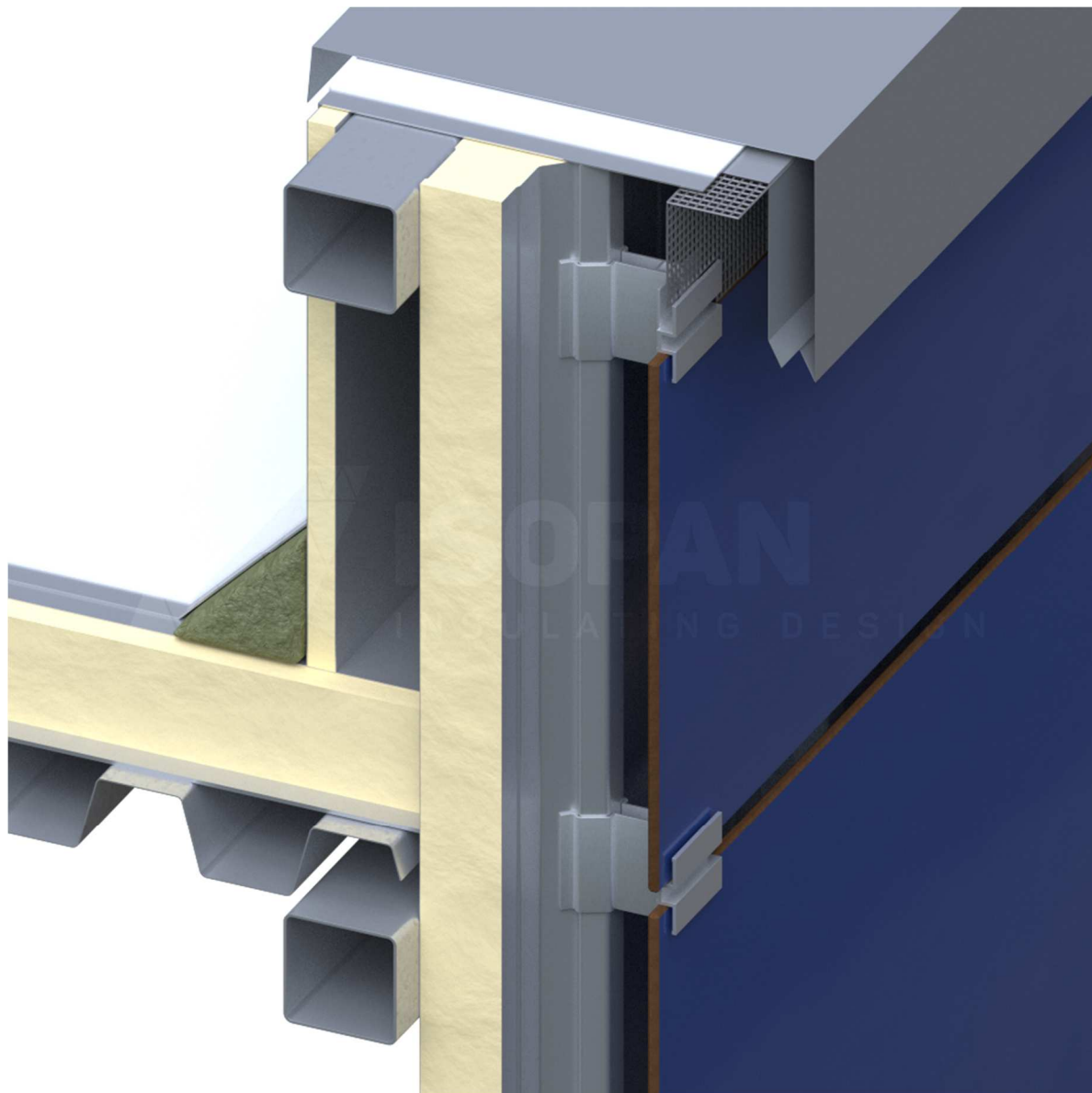

ISOPAN

SPV 24

Isocop Multifunzione and ventilated façade system [Roof]

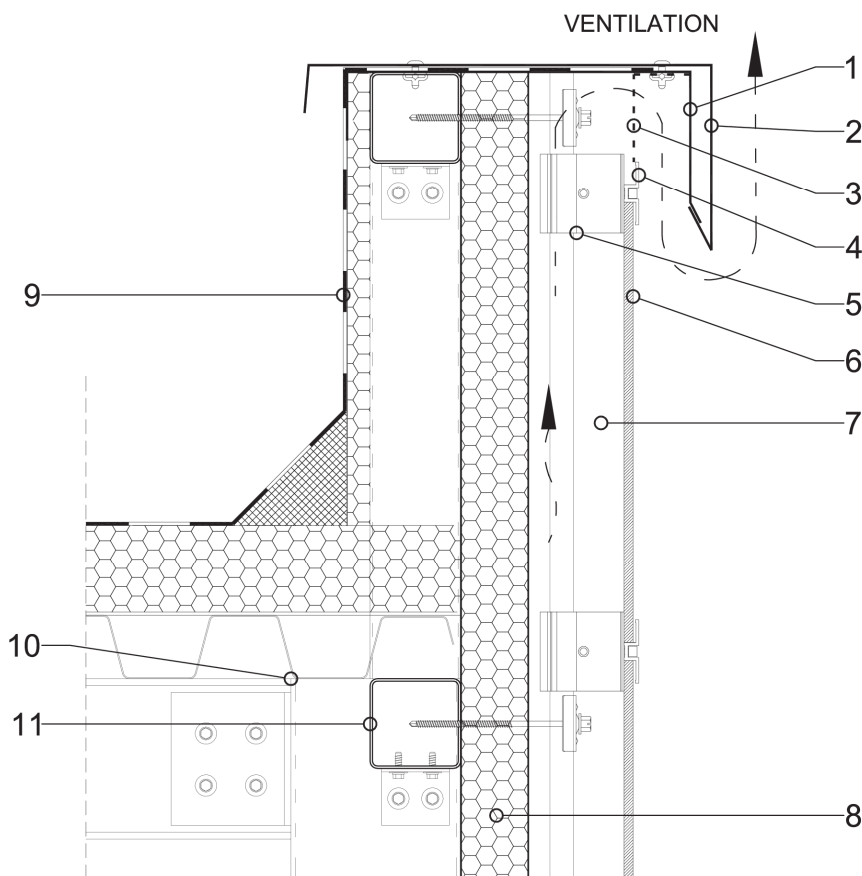

The designer is responsible for assessing the need to insert additional gasket and/or closing elements, even when not indicated in the drawing details.

Key

1	Support tinwork
2	Finishing tinwork
3	Ventilation grille
4	Retainer clamp for façade panel
5	Bracket for ISOCOP MULTIFUNZIONE
6	Façade panel
7	Ventilation air chamber
8	ISOCOP MULTIFUNZIONE panel
9	Waterproofing Membrane
10	Load-bearing metal structure
11	Secondary load-bearing metal structure

ATTENTION: the proposed solution does not represent a project, and must be examined and assessed prior by the designer or Clerk of Works. The property rights of this document belong exclusively to ISOPAN S.p.a. Reproduction even in part without prior written authorisation by the author is forbidden. To choose the type of fastening, please refer to the screw type choice sheet; To choose the screw length, please refer to the data sheet for the correct screw length.

ISOCOP MULTIFUNZIONE AND FALSE CEILING SYSTEM



Isocop Multifunzione and false ceiling system

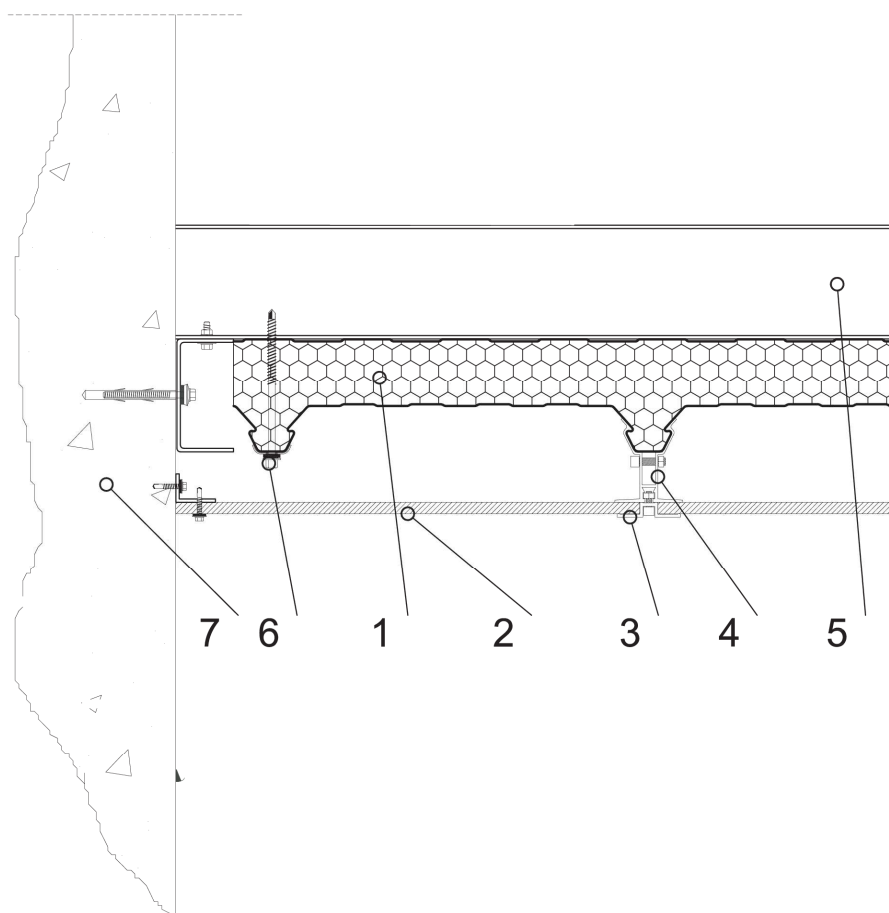

The designer is responsible for assessing the need to insert additional gasket and/or closing elements, even when not indicated in the drawing details.

Key

1	ISOPAN roof panel (e.g. ISOCOP MULTIFUNZIONE)
2	Plasterboard false ceiling
3	Retainer clamp for visible plasterboard panel
4	Bracket for ISOCOP MULTIFUNZIONE panel
5	Steel load-bearing structure
6	Fastening unit
7	Concrete wall

ATTENTION: the proposed solution does not represent a project, and must be examined and assessed prior by the designer or Clerk of Works. The property rights of this document belong exclusively to ISOPAN S.p.a. Reproduction even in part without prior written authorisation by the author is forbidden. To choose the type of fastening, please refer to the screw type choice sheet; To choose the screw length, please refer to the data sheet for the correct screw length.

CANTILEVER ROOF WALL CONNECTION WITH GUTTER

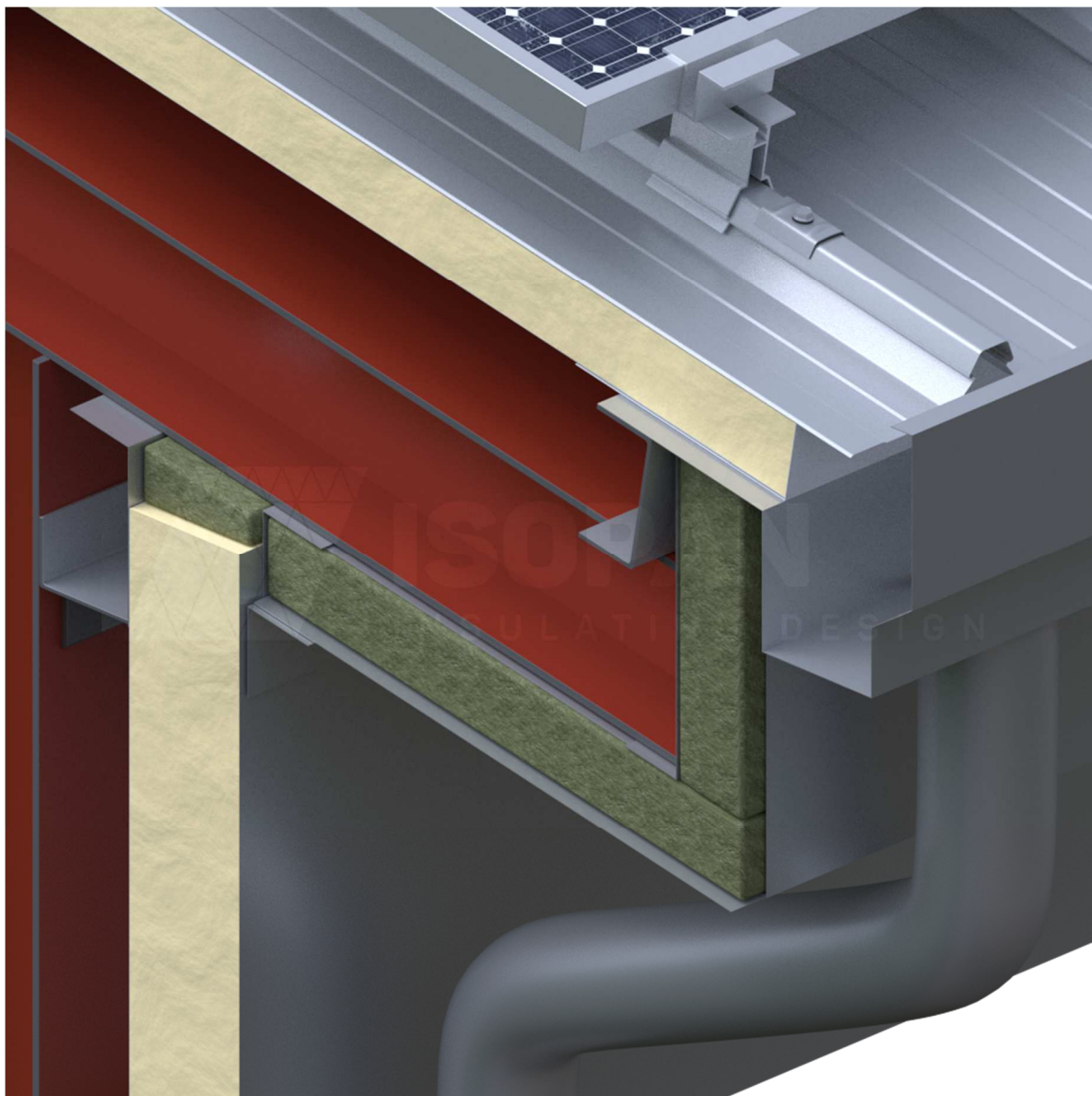

Type 2 roof wall connection with gutter

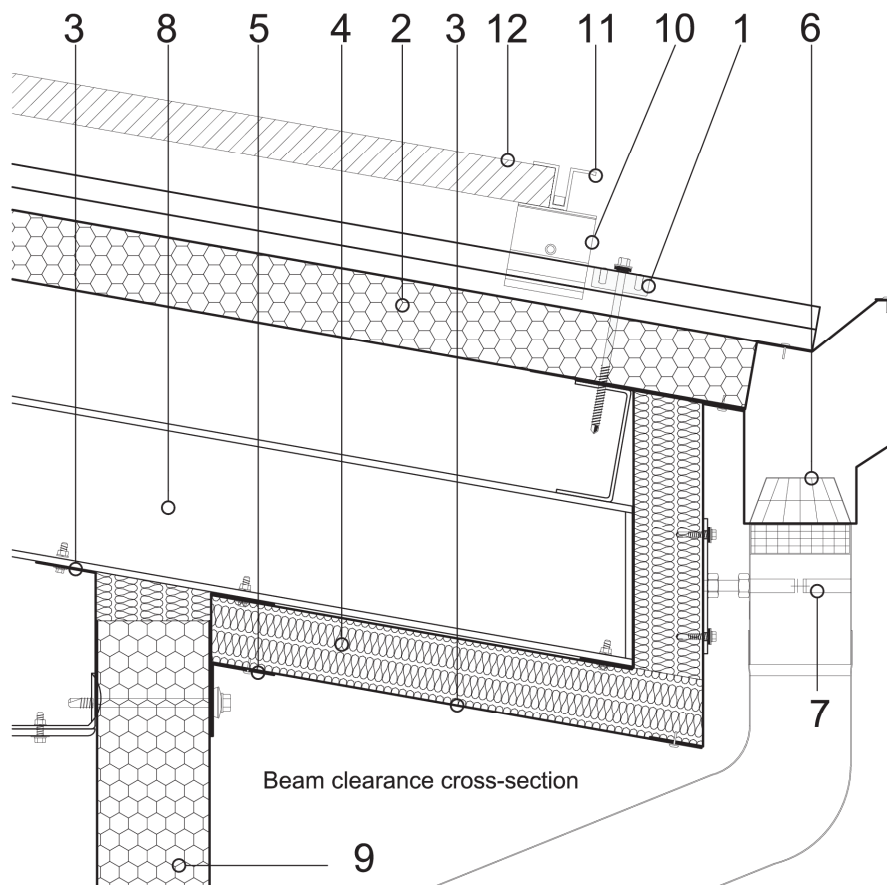

The designer is responsible for assessing the need to insert additional gasket and/or closing elements, even when not indicated in the drawing details.

Key

1	Roof panel fastening unit
2	ISOPAN roof panel (e.g. ISOCOP MULTIFUNZIONE)
3	Closing metal sheet
4	Mineral wool
5	Rivet
6	Leaf screen
7	Gutter fastening unit
8	Main steel structure
9	ISOPAN wall panel
10	Bracket for ISOCOP MULTIFUNZIONE panel
11	Retainer clamp for photovoltaic system structure
12	Photovoltaic system

ATTENTION: the proposed solution does not represent a project, and must be examined and assessed prior by the designer or Clerk of Works. The property rights of this document belong exclusively to ISOPAN S.p.a. Reproduction even in part without prior written authorisation by the author is forbidden. To choose the type of fastening, please refer to the screw type choice sheet; To choose the screw length, please refer to the data sheet for the correct screw length.

FLAT ROOF WALL CONNECTION

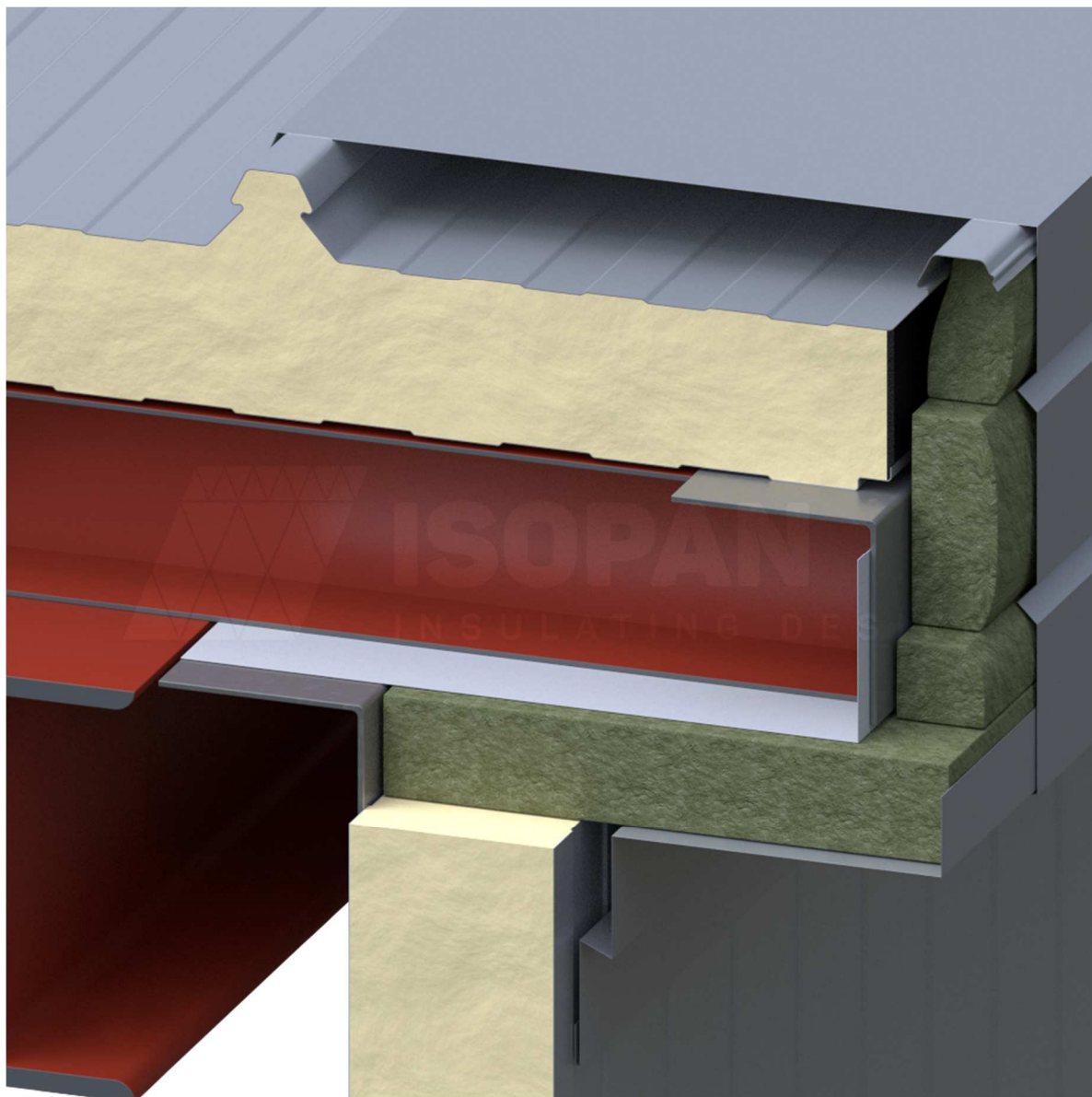

ISOPAN

RPCV 13cm

Roof wall side connection

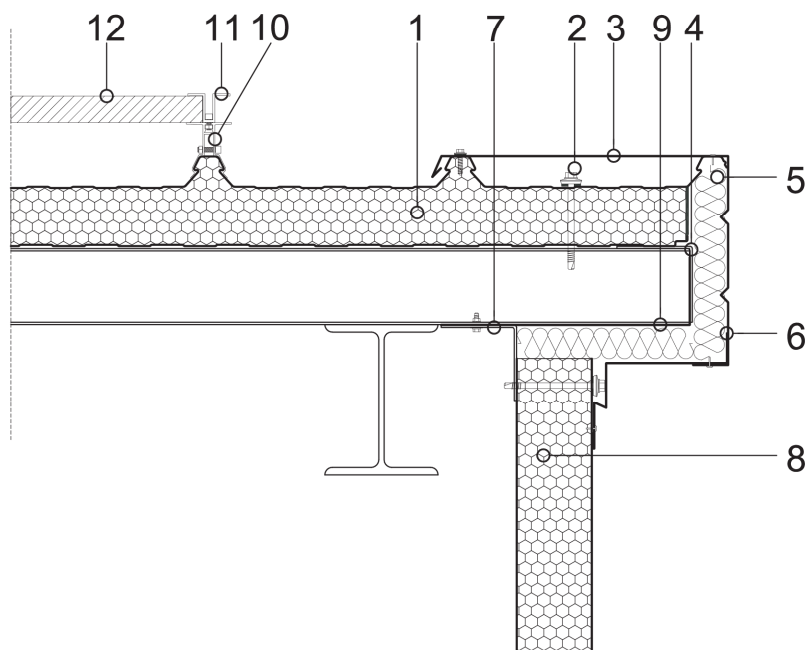

The designer is responsible for assessing the need to insert additional gasket and/or closing elements, even when not indicated in the drawing details.

Key

1	ISOPAN roof panel (e.g. ISOCOP MULTIFUNZIONE)
2	Roof panel fastening screw
3	Protective metal sheet
4	L-shaped closing metal sheet
5	Mineral wool insulating material
6	Protective metal sheet
7	Internal closing metal sheet
8	ISOPAN wall panel
9	L-shaped closing metal sheet
10	Bracket for ISOCOP MULTIFUNZIONE panel
11	Retainer clamp for photovoltaic system structure
12	Photovoltaic system

ATTENTION: the proposed solution does not represent a project, and must be examined and assessed prior by the designer or Clerk of Works. The property rights of this document belong exclusively to ISOPAN S.p.a. Reproduction even in part without prior written authorisation by the author is forbidden. To choose the type of fastening, please refer to the screw type choice sheet; To choose the screw length, please refer to the data sheet for the correct screw length.

ROOF WALL CONNECTION WITH INSULATED GUTTER WITH PARAPET

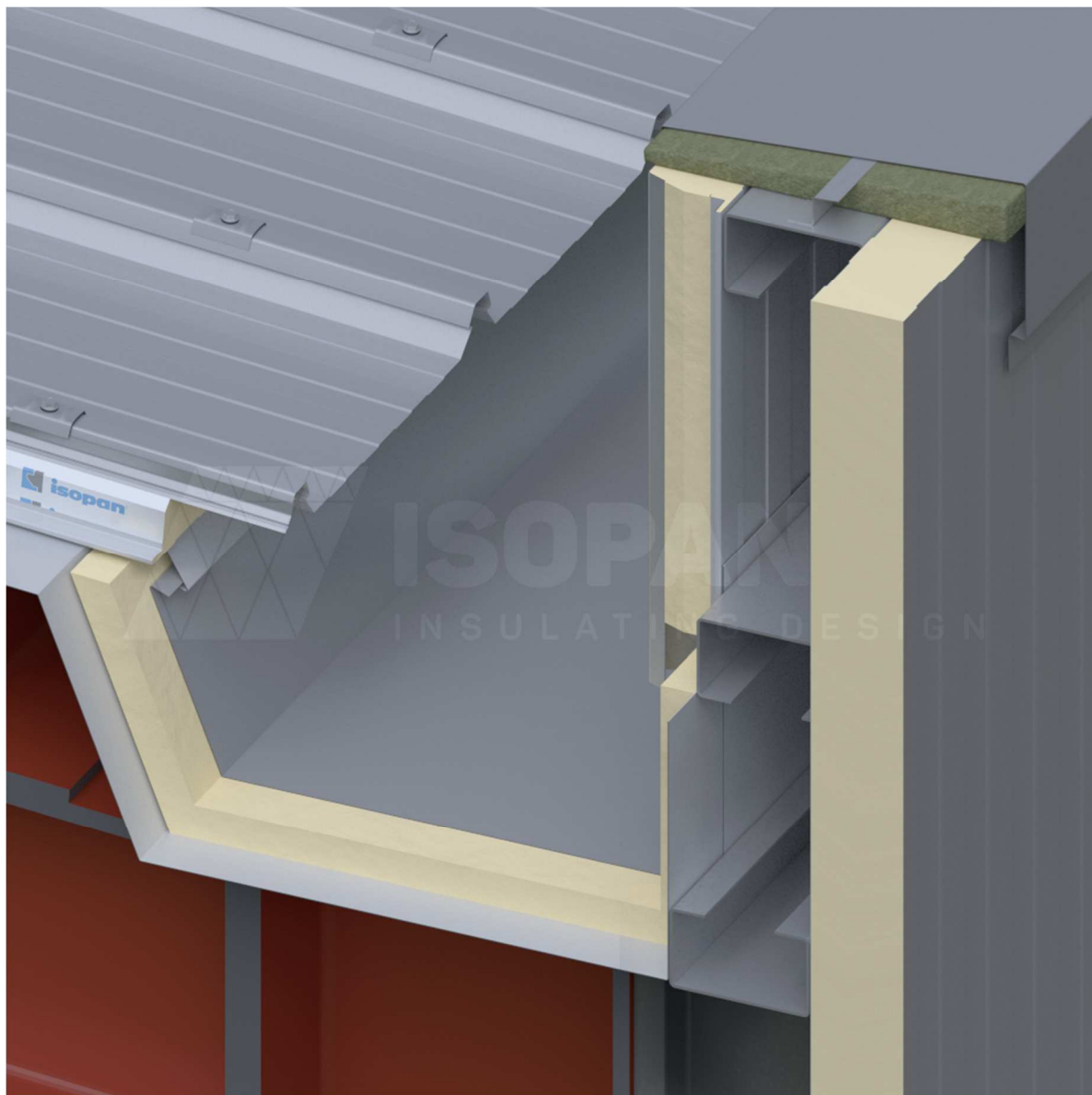

ISOPAN

RPCV 14cm

Type 4 roof wall connection with insulated gutter

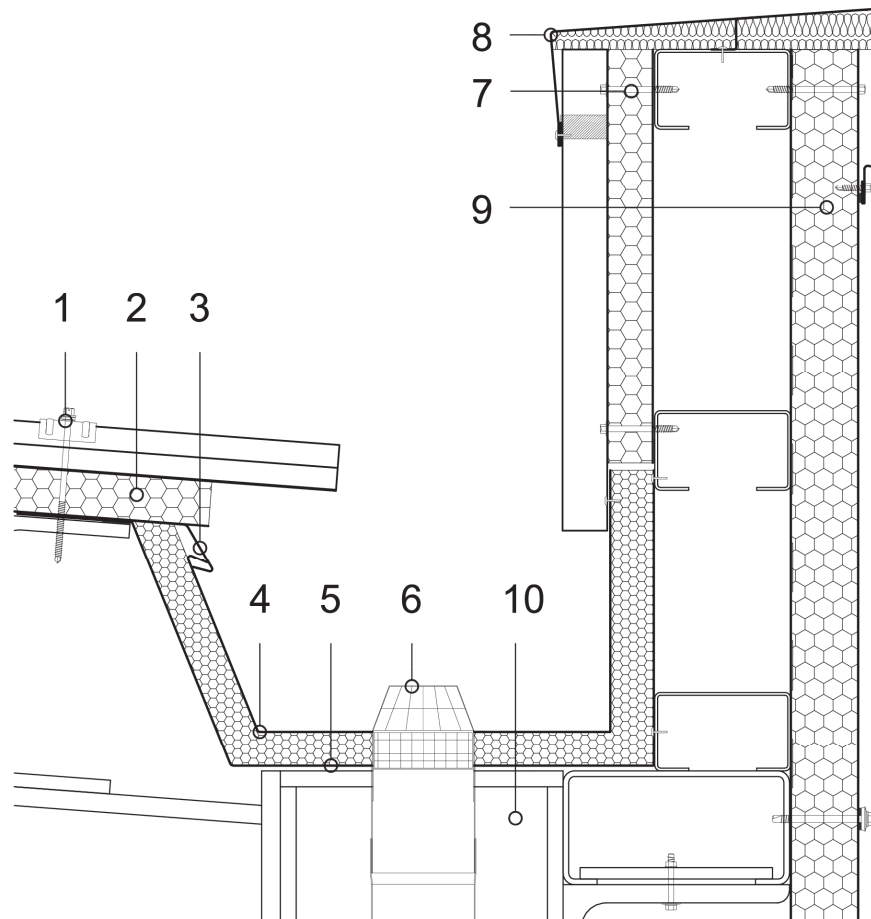

The designer is responsible for assessing the need to insert additional gasket and/or closing elements, even when not indicated in the drawing details.

Key

1	Roof panel fastening unit
2	ISOPAN roof panel (e.g. ISOCOP MULTIFUNZIONE)
3	Drip edge metal sheet
4	Gutter metal sheet
5	Eaves metal sheet
6	Leaf screen
7	Through fastening screw
8	Railing protection metal sheet
9	ISOPAN wall panel
10	Main steel structure

ATTENTION: the proposed solution does not represent a project, and must be examined and assessed prior by the designer or Clerk of Works. The property rights of this document belong exclusively to ISOPAN S.p.a. Reproduction even in part without prior written authorisation by the author is forbidden. To choose the type of fastening, please refer to the screw type choice sheet; To choose the screw length, please refer to the data sheet for the correct screw length.

ROOF WALL CONNECTION WITH GUTTER

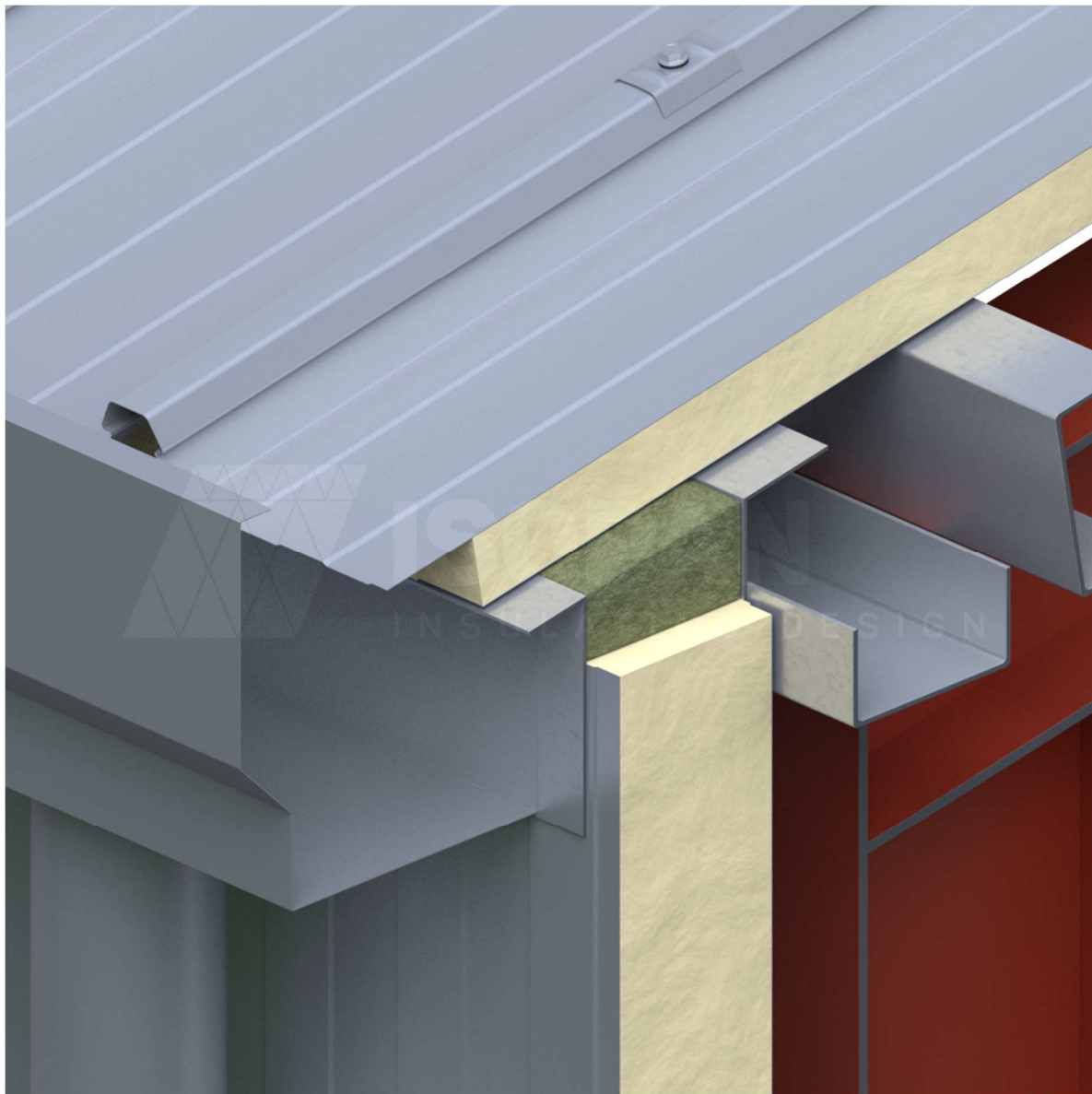

Type 1 roof wall connection with outer gutter

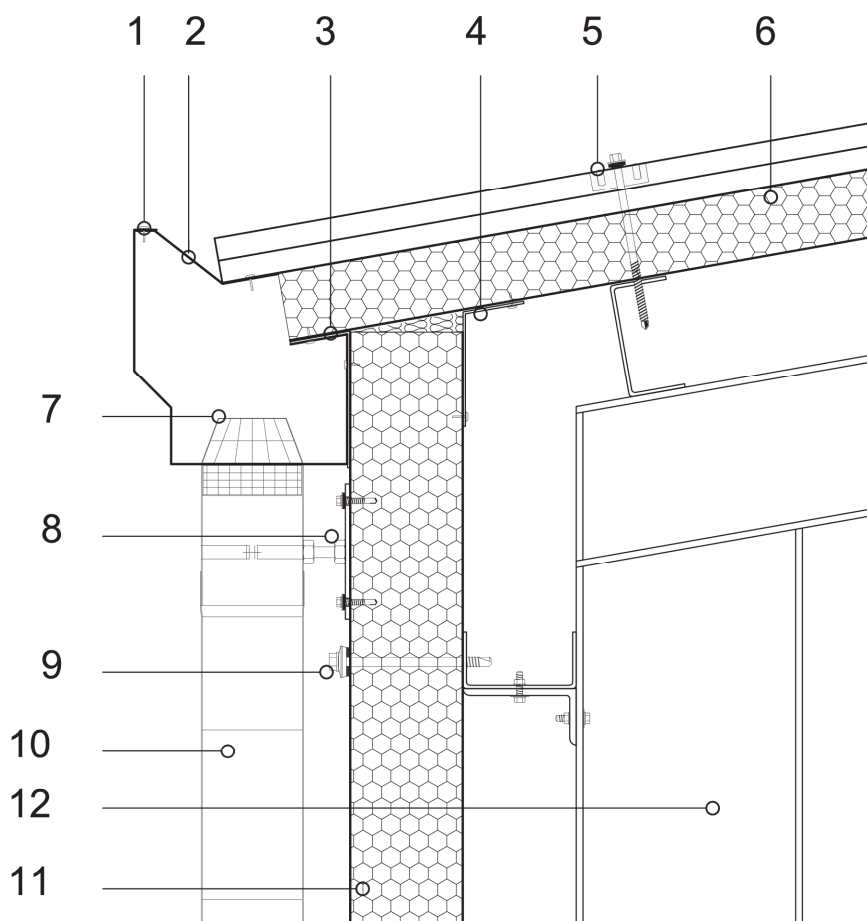

The designer is responsible for assessing the need to insert additional gasket and/or closing elements, even when not indicated in the drawing details.

Key

1	Rivet	11	ISOPAN wall panel
2	Gutter support metal sheet	12	Main structure
3	External corner metal sheet closing		
4	Internal corner metal sheet closing		
5	Roof panel fastening unit		
6	ISOPAN roof panel (e.g. ISOCOP MULTIFUNZIONE)		
7	Leaf screen		
8	Gutter fastening unit		
9	Through fastening screw		
10	Gutter		

ATTENTION: the proposed solution does not constitute the project, and must be firstly assessed and evaluated by the designer and construction supervision. The property rights of this document belong to ISOPAN S.p.a.. The contents can't be reproduced without prior written permission by the author. To choose the type of fastening, please refer to the screw type choice sheet; To choose the screw length, please refer to the data sheet for the correct screw length).

ROOF WALL CONNECTION WITH SINGLE ROOF PITCH RIDGE

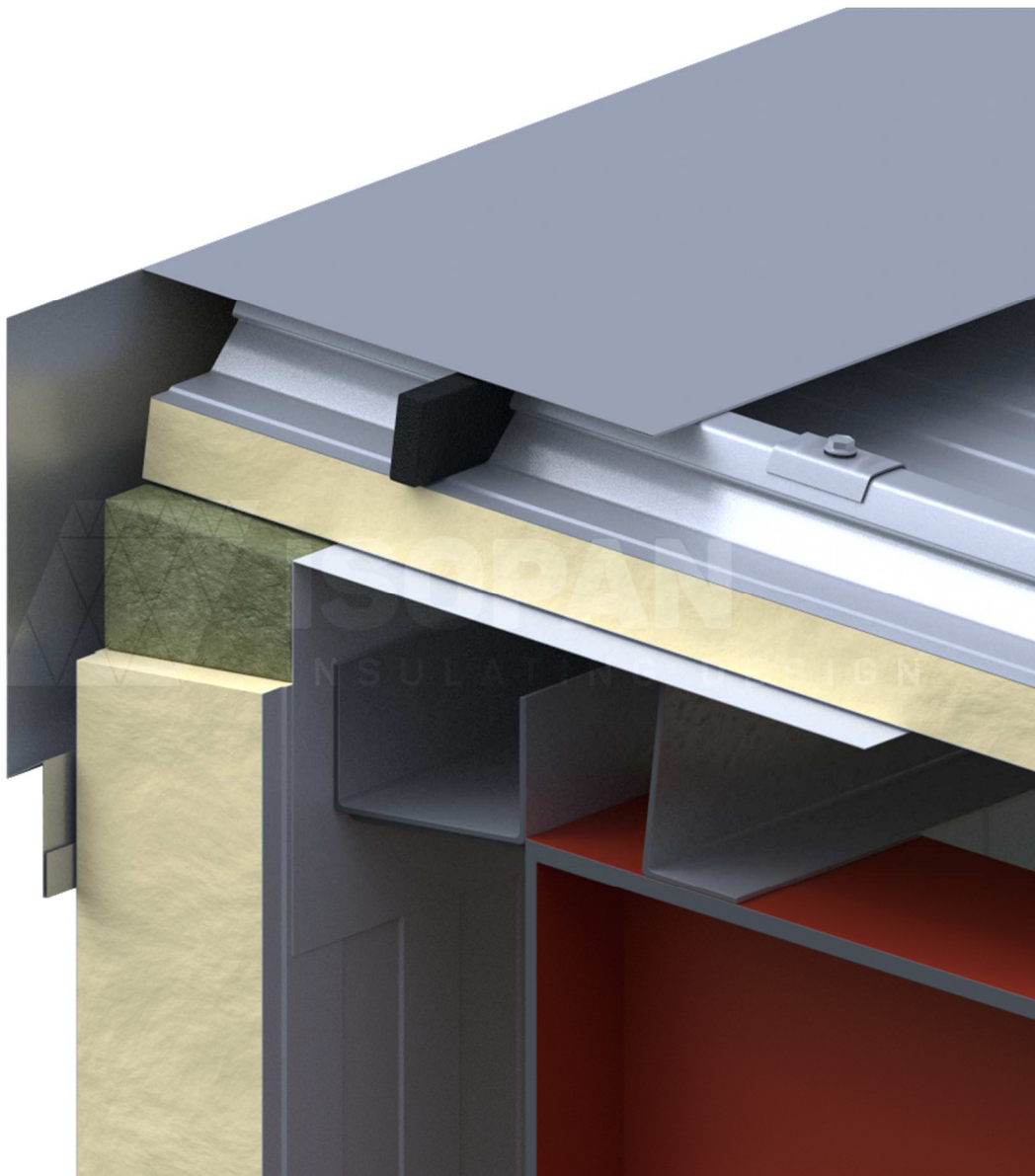



RPCV 04cm

Type 1 roof wall connection

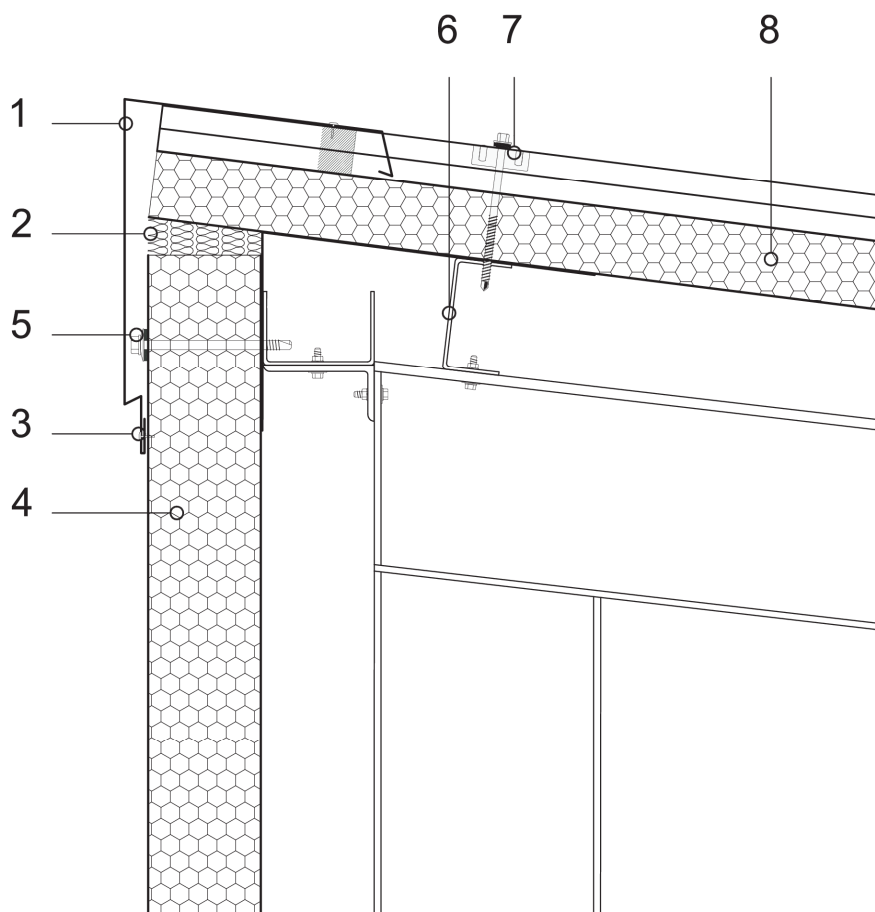

The designer is responsible for assessing the need to insert additional gasket and/or closing elements, even when not indicated in the drawing details.

Key

1	Closing metal sheet
2	Polyurethane foam insulating material
3	Rivet
4	ISOPAN wall panel
5	Through fastening screw
6	Secondary steel structure
7	Roof - metal sheet through fastening screw
8	ISOPAN roof panel (e.g. ISOCOP MULTIFUNZIONE)

ATTENTION: the proposed solution does not represent a project, and must be examined and assessed prior by the designer or Clerk of Works. The property rights of this document belong exclusively to ISOPAN S.p.a. Reproduction even in part without prior written authorisation by the author is forbidden. To choose the type of fastening, please refer to the screw type choice sheet; To choose the screw length, please refer to the data sheet for the correct screw length.

ROOF WALL CONNECTION WITH INSULATED GUTTER

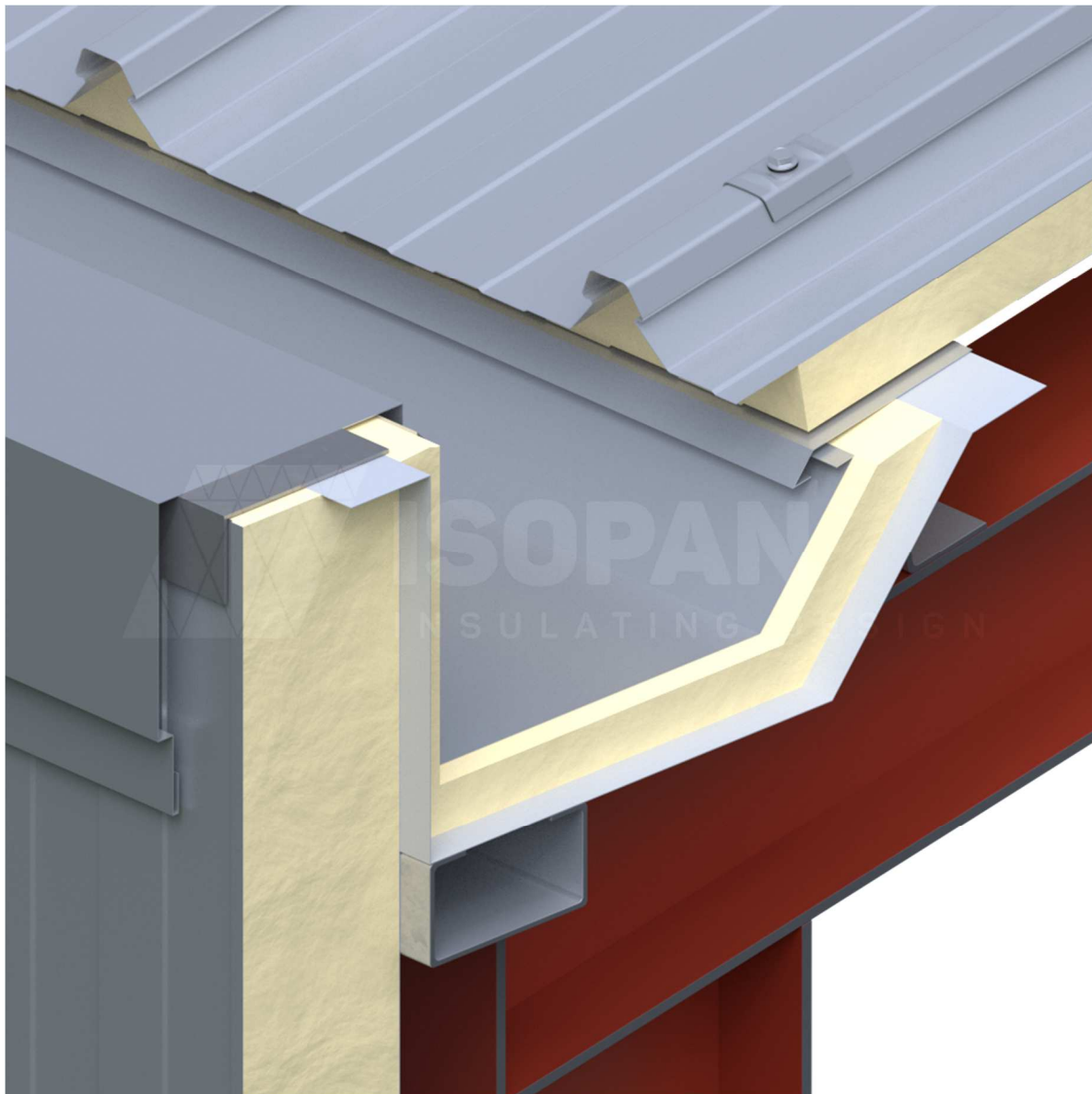

Roof wall connection with insulated gutter

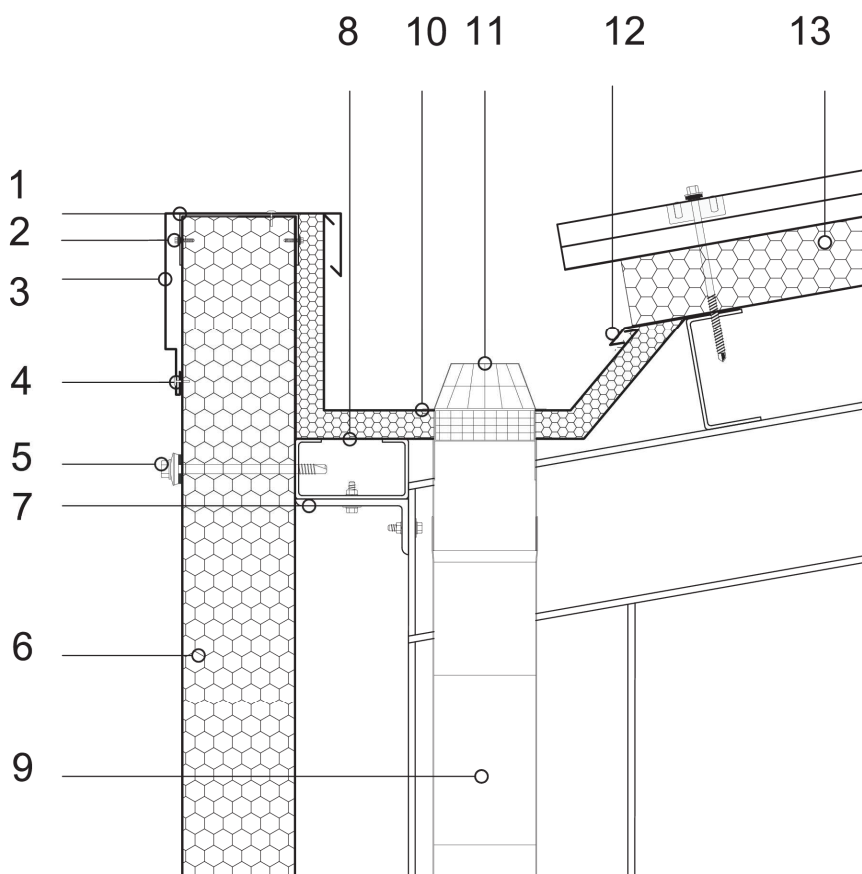

The designer is responsible for assessing the need to insert additional gasket and/or closing elements, even when not indicated in the drawing details.

Key

1	Head closing metal sheet	11	Leaf screen
2	Fastening screw	12	Drip edge metal sheet
3	Protective metal sheet	13	ISOPAN roof panel (e.g. ISOCOP MULTIFUNZIONE)
4	Rivet		
5	Through fastening screw		
6	ISOPAN wall panel		
7	Steel load-bearing structure		
8	Eaves metal sheet		
9	Drainpipe		
10	Gutter		

ATTENTION: the proposed solution does not represent a project, and must be examined and assessed prior by the designer or Clerk of Works. The property rights of this document belong exclusively to ISOPAN S.p.a. Reproduction even in part without prior written authorisation by the author is forbidden. To choose the type of fastening, please refer to the screw type choice sheet; To choose the screw length, please refer to the data sheet for the correct screw length.

DUAL-PITCH ROOF SINGLE PIECE RIDGE

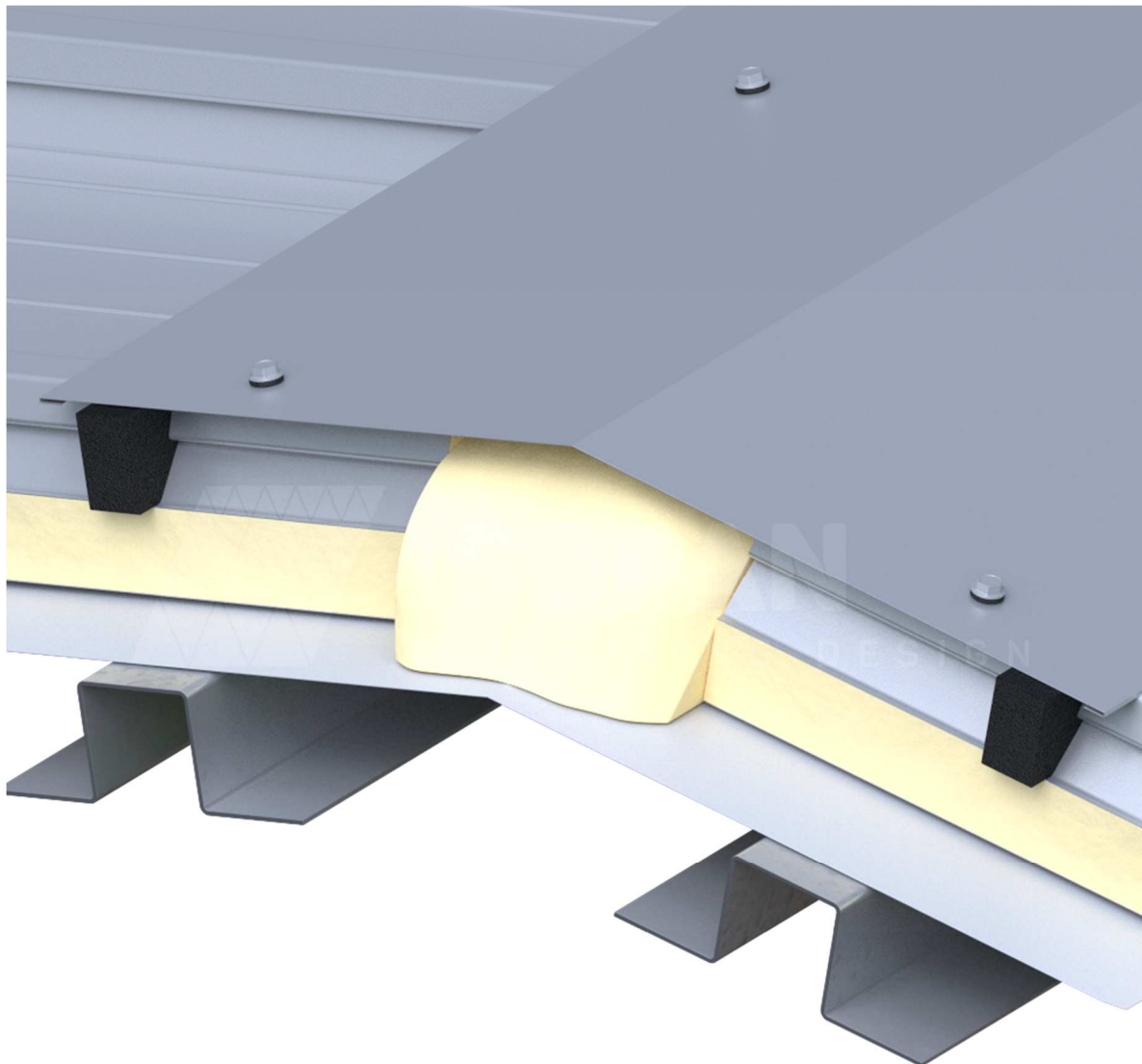

 **ISOPAN**

SCV 01cm

Type 1 roof ridge: vertical cross-section

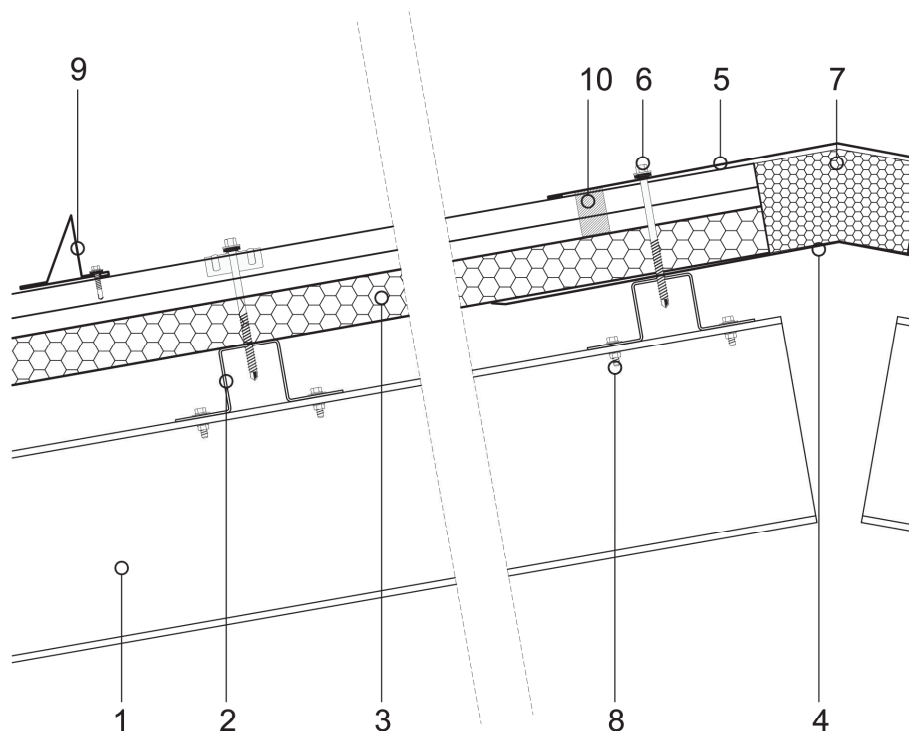

The designer is responsible for assessing the need to insert additional gasket and/or closing elements, even when not indicated in the drawing details.

Key

1	Steel structure profile
2	Steel standard profile
3	ISOPAN roof panel (e.g. ISOCOP MULTIFUNZIONE)
4	Under-ridge internal ridge cap
5	Flat ridge
6	Roof panel and ridge fastening screw
7	Polyurethane or mineral wool insulating material
8	Structural fastening screw
9	Snow guard
10	Rib closing gasket

ATTENTION: the proposed solution does not represent a project, and must be examined and assessed prior by the designer or Clerk of Works. The property rights of this document belong exclusively to ISOPAN S.p.a. Reproduction even in part without prior written authorisation by the author is forbidden. To choose the type of fastening, please refer to the screw type choice sheet; To choose the screw length, please refer to the data sheet for the correct screw length.

DUAL-PITCH ROOF HINGED RIDGE

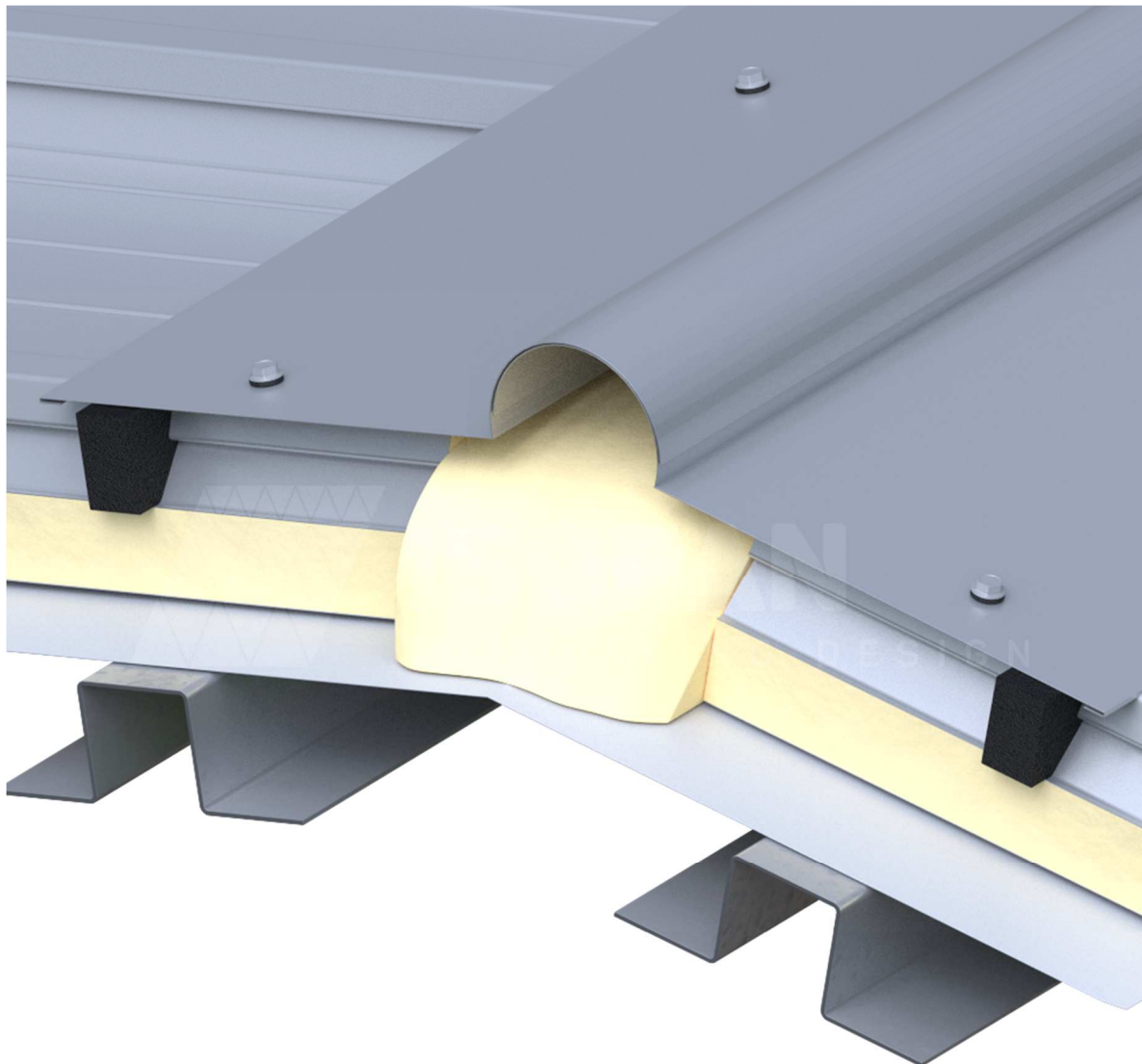

ISOPAN

SCV 02cm

Type 2 roof ridge: vertical cross-section

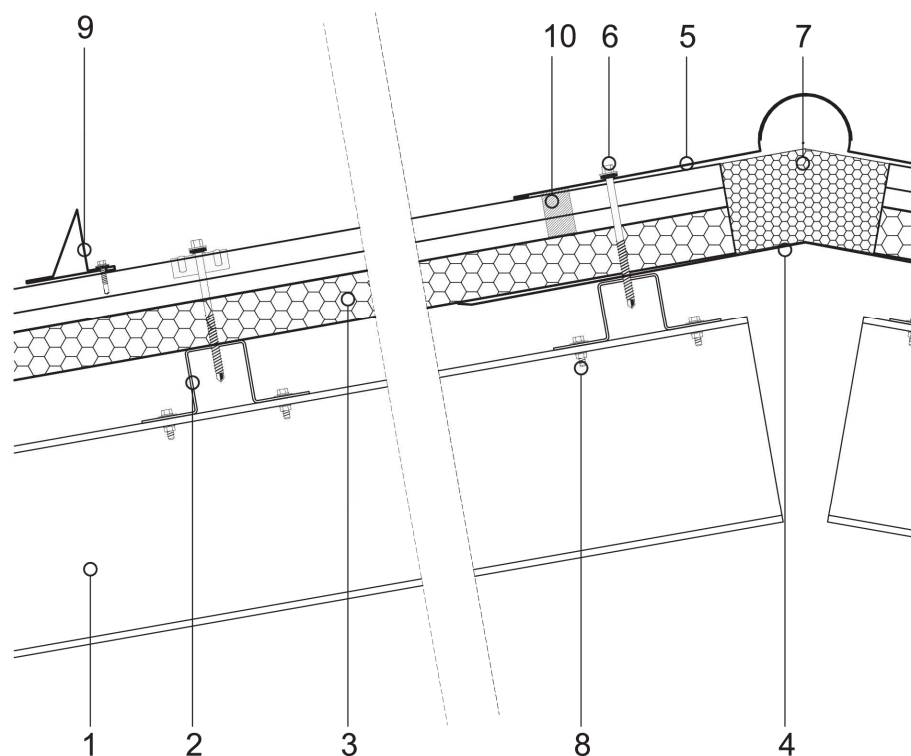

The designer is responsible for assessing the need to insert additional gasket and/or closing elements, even when not indicated in the drawing details.

Key

1	Steel structure profile
2	Steel standard profile
3	ISOPAN roof panel (e.g. ISOCOP MULTIFUNZIONE)
4	Under-ridge internal ridge cap
5	Flat hinged ridge
6	Roof panel and ridge fastening screw
7	Polyurethane or mineral wool insulating material
8	Structural fastening screw
9	Snow guard
10	Rib closing gasket

ATTENTION: the proposed solution does not represent a project, and must be examined and assessed prior by the designer or Clerk of Works. The property rights of this document belong exclusively to ISOPAN S.p.a. Reproduction even in part without prior written authorisation by the author is forbidden. To choose the type of fastening, please refer to the screw type choice sheet; To choose the screw length, please refer to the data sheet for the correct screw length.

FLAT ROOF WALL CONNECTION

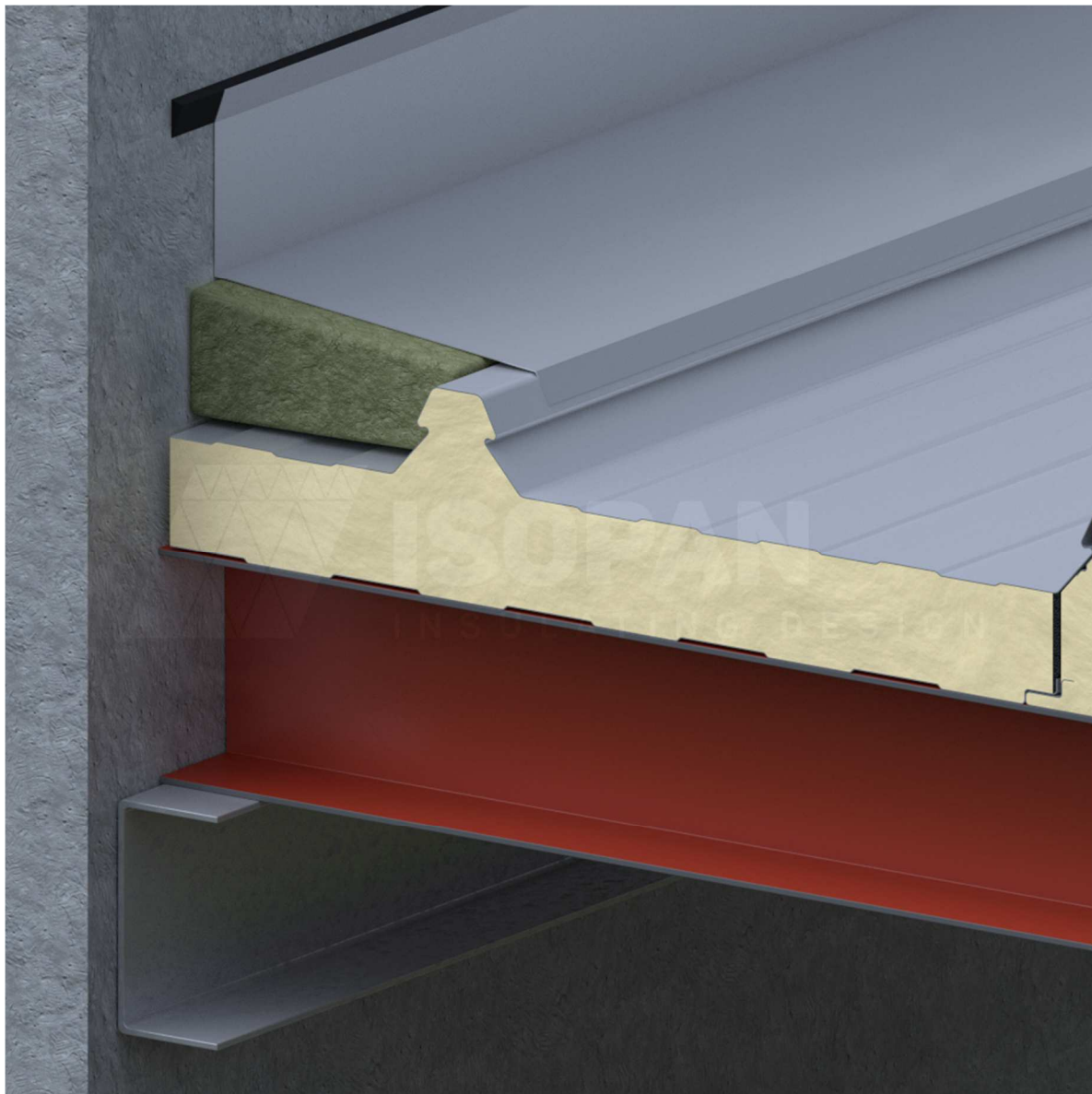

ISOPAN

SCV 03cm

Type 1 roof detail

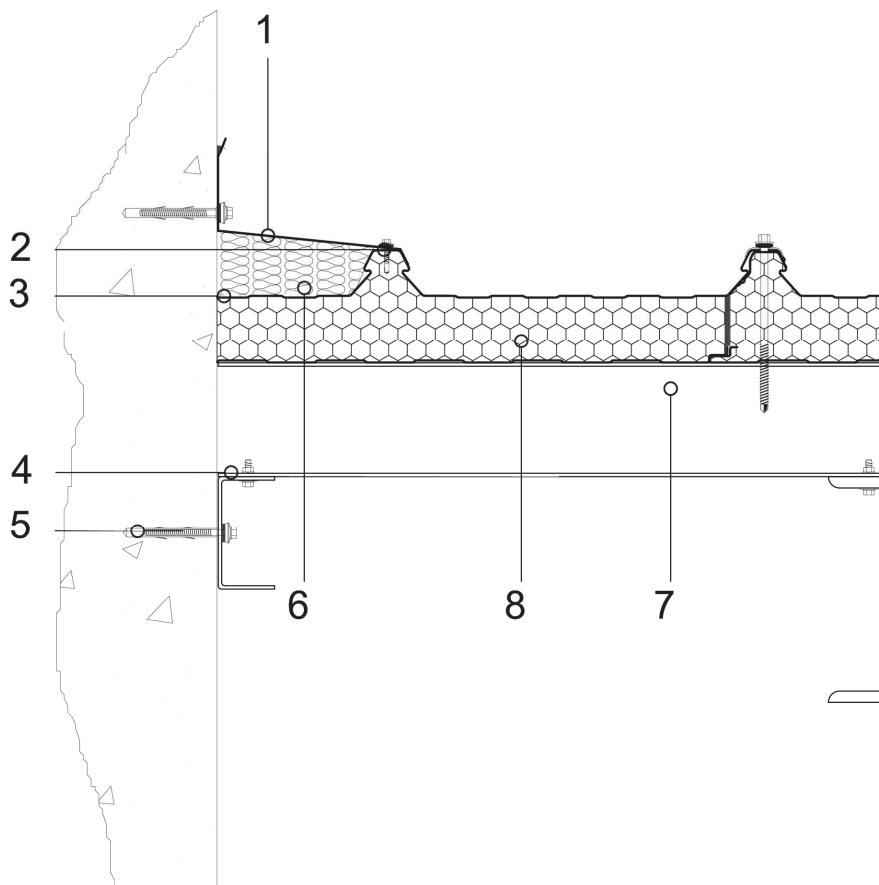

The designer is responsible for assessing the need to insert additional gasket and/or closing elements, even when not indicated in the drawing details.

Key

1	Liner ridge cap
2	Closing corner metal sheet
3	Self-tapping fastening screw
4	Steel C-shaped profile
5	Main structure fastening screw
6	Mineral wool insulating material
7	Roof panel fastening unit
8	ISOPAN roof panel (e.g. ISOCOP MULTIFUNZIONE)

ATTENTION: the proposed solution does not represent a project, and must be examined and assessed prior by the designer or Clerk of Works. The property rights of this document belong exclusively to ISOPAN S.p.a. Reproduction even in part without prior written authorisation by the author is forbidden. To choose the type of fastening, please refer to the screw type choice sheet; To choose the screw length, please refer to the data sheet for the correct screw length.

INCLINED ROOF WALL CONNECTION

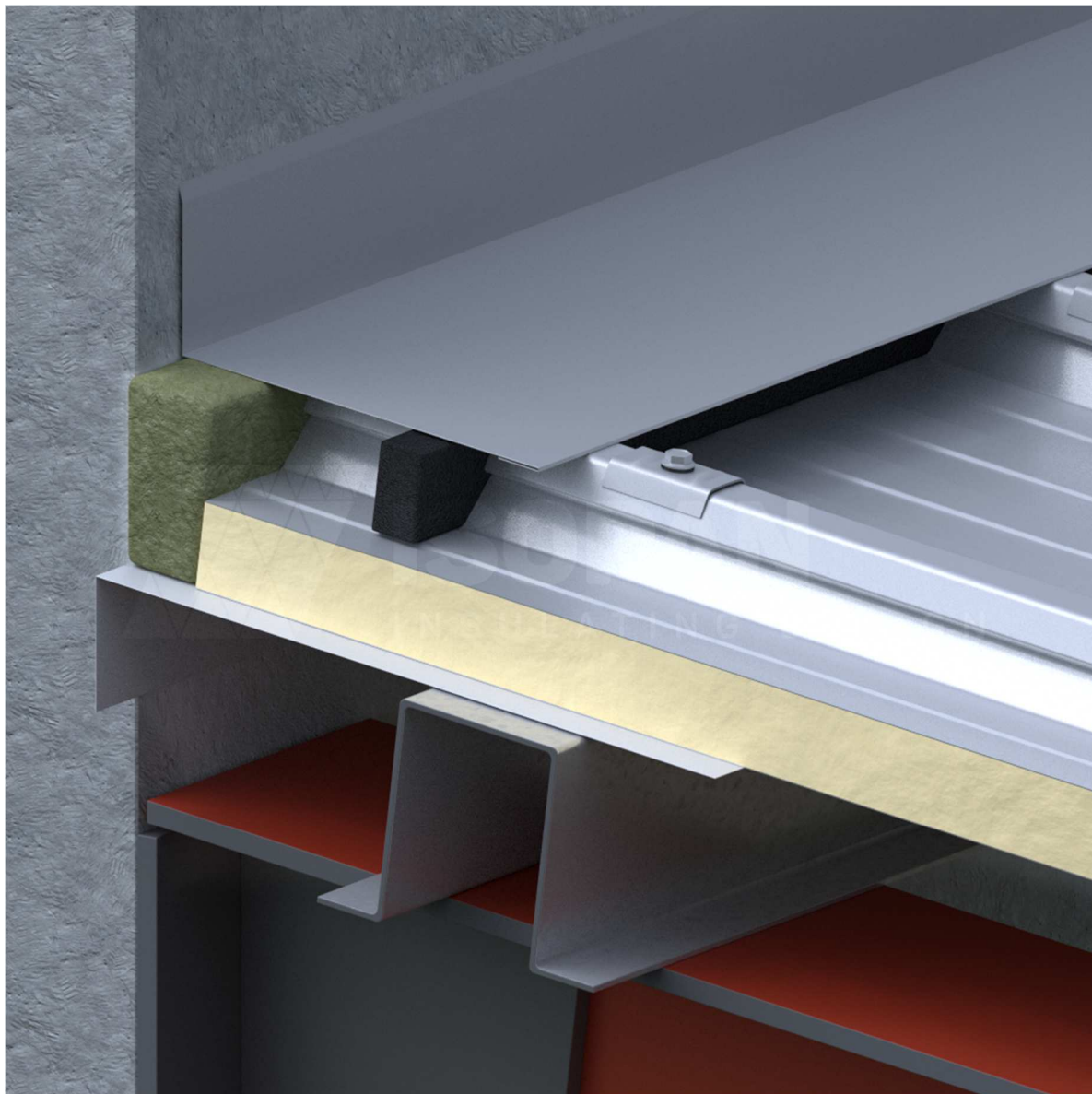

ISOPAN

SCV 04cm

Type 2 roof detail

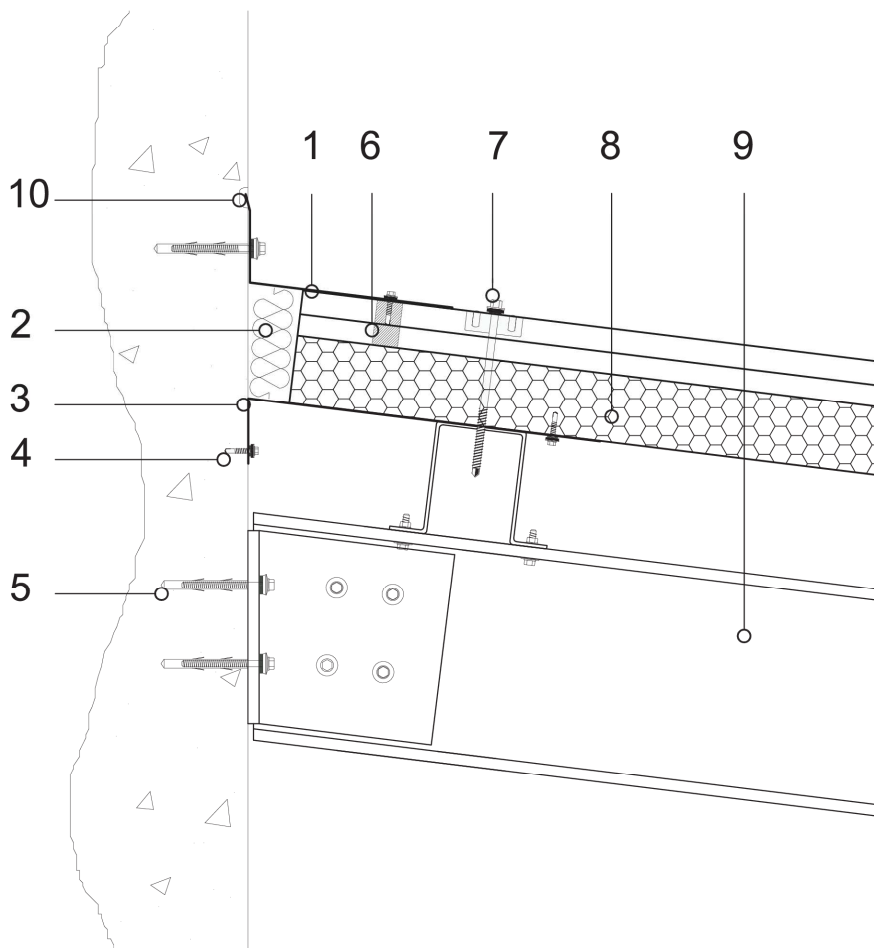

The designer is responsible for assessing the need to insert additional gasket and/or closing elements, even when not indicated in the drawing details.

Key

1	Liner ridge cap
2	Mineral wool insulating material
3	Closing corner metal sheet
4	Metal sheet fastening screw
5	Main structure fastening screw
6	Rib closing gasket
7	Roof panel fastening unit
8	ISOPAN roof panel (e.g. ISOCOP MULTIFUNZIONE)
9	Main steel structure
10	Silicone sealing

ATTENTION: the proposed solution does not represent a project, and must be examined and assessed prior by the designer or Clerk of Works. The property rights of this document belong exclusively to ISOPAN S.p.a. Reproduction even in part without prior written authorisation by the author is forbidden. To choose the type of fastening, please refer to the screw type choice sheet; To choose the screw length, please refer to the data sheet for the correct screw length.

ROOF CONNECTION ON VALLEY GUTTER

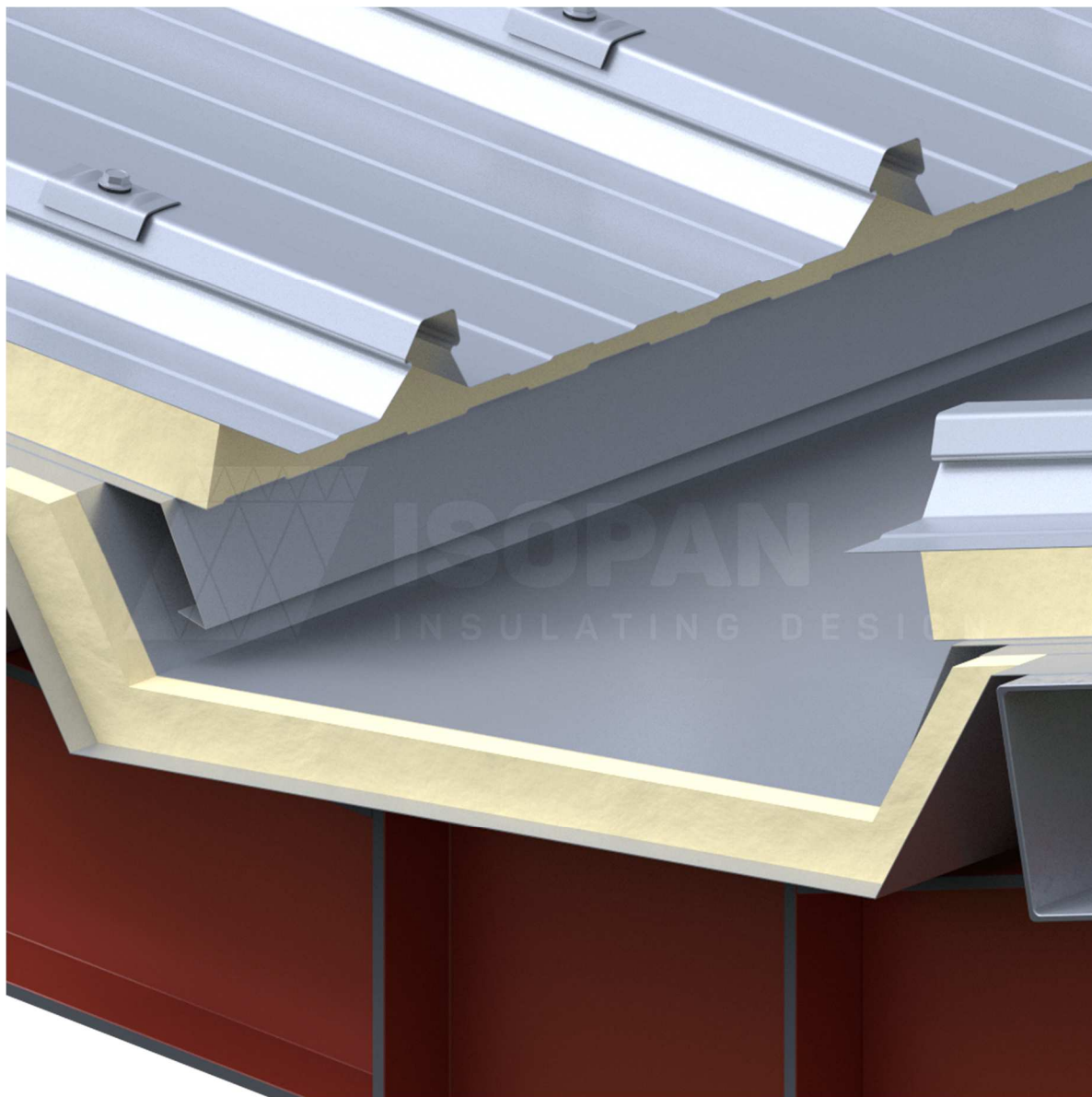

ISOPAN

SCV 05cm

Type 1 gutter with valley detail

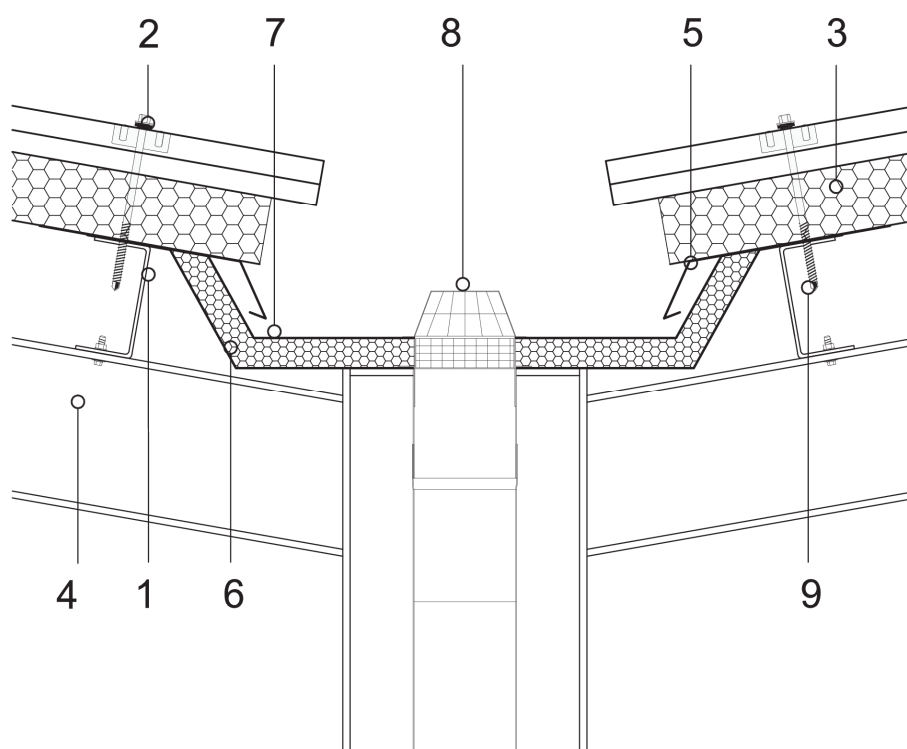

The designer is responsible for assessing the need to insert additional gasket and/or closing elements, even when not indicated in the drawing details.

Key

1	Secondary steel structure
2	Roof panel fastening unit
3	ISOPAN roof panel (e.g. ISOCOP MULTIFUNZIONE)
4	Main steel structure
5	Drip edge metal sheet
6	Eaves metal sheet
7	Gutter metal sheet
8	Leaf screen
9	Fastening screw

ATTENTION: the proposed solution does not represent a project, and must be examined and assessed prior by the designer or Clerk of Works. The property rights of this document belong exclusively to ISOPAN S.p.a. Reproduction even in part without prior written authorisation by the author is forbidden. To choose the type of fastening, please refer to the screw type choice sheet; To choose the screw length, please refer to the data sheet for the correct screw length.

OVERLAP FASTENING

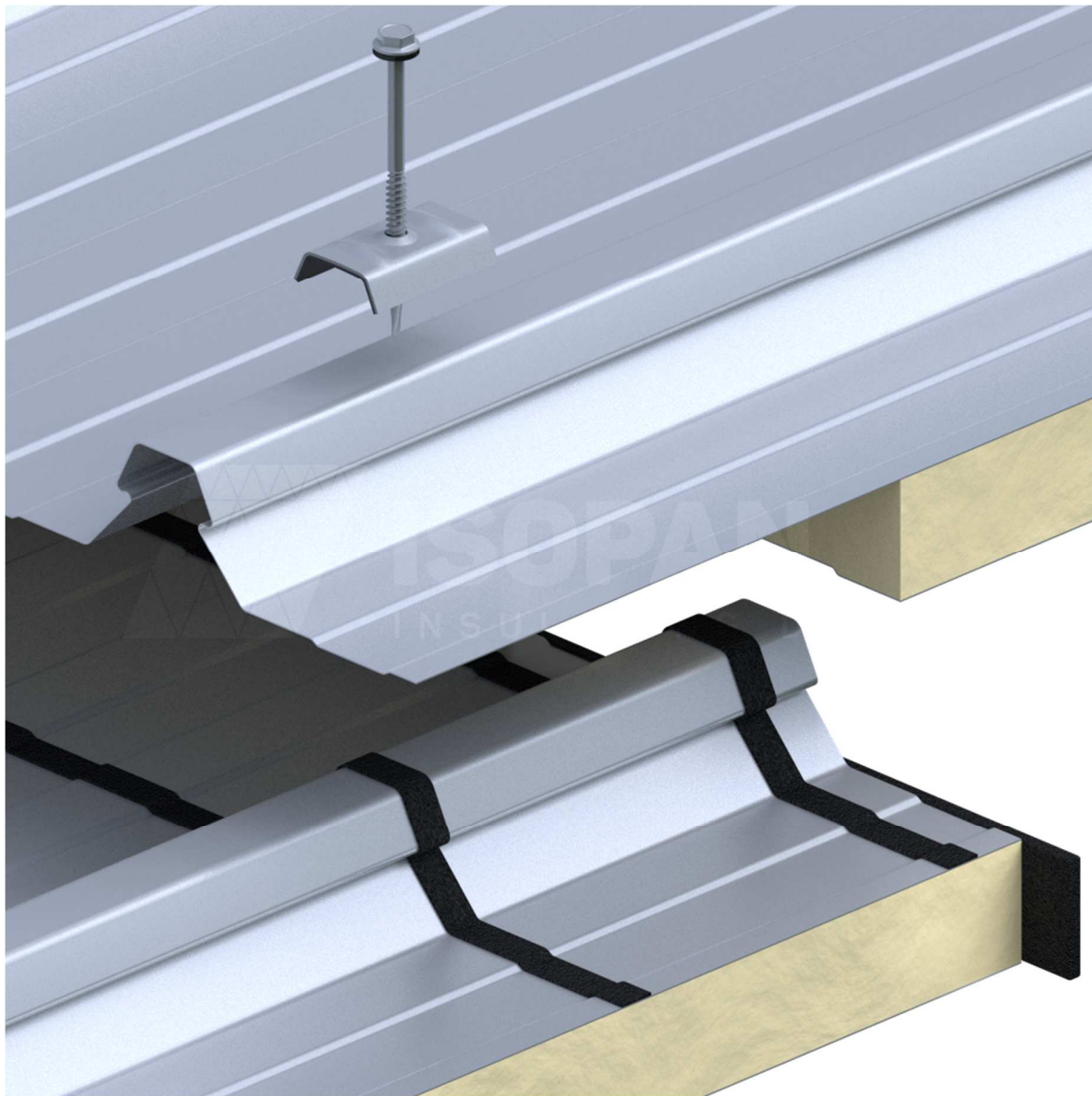



SCV 24cm

Head overlap cross-section

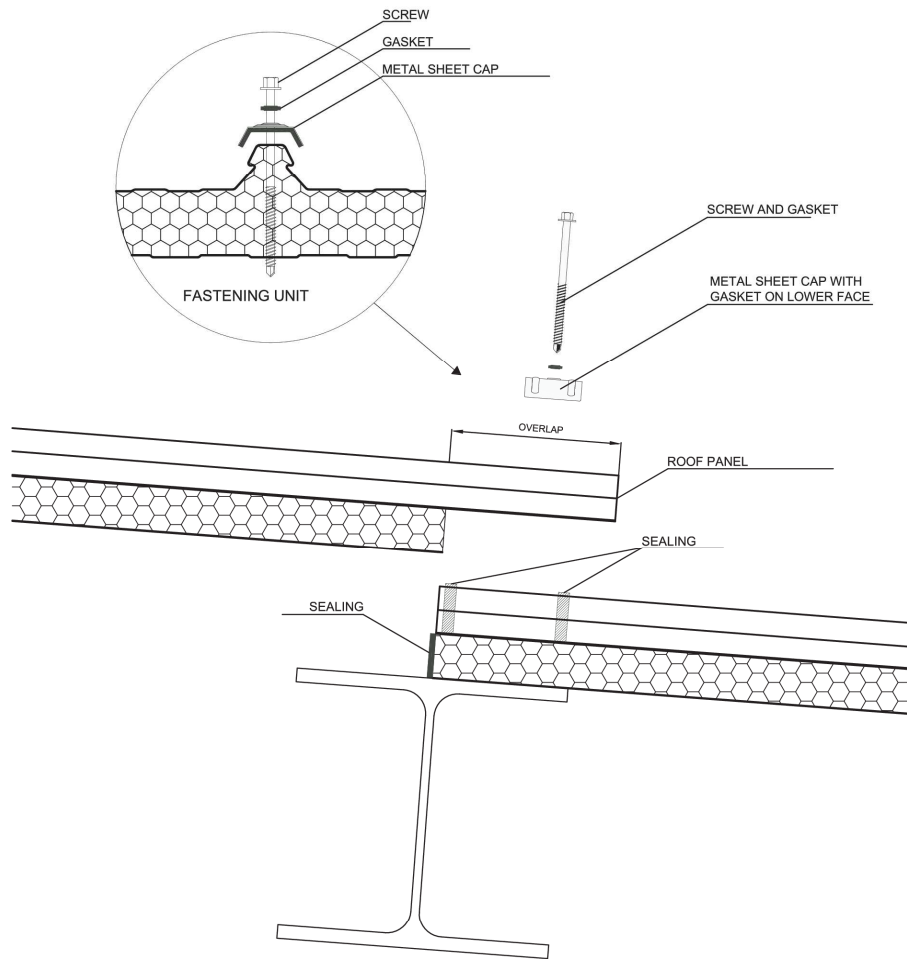

ATTENTION: the proposed solution does not represent a project, and must be examined and assessed prior by the designer or Clerk of Works. The property rights of this document belong exclusively to ISOPAN S.p.a. Reproduction even in part without prior written authorisation by the author is forbidden. To choose the type of fastening, please refer to the screw type choice sheet; To choose the screw length, please refer to the data sheet for the correct screw length.

STITCHING SCREW POSITIONING





SCV 25cm

Head overlap cross-section

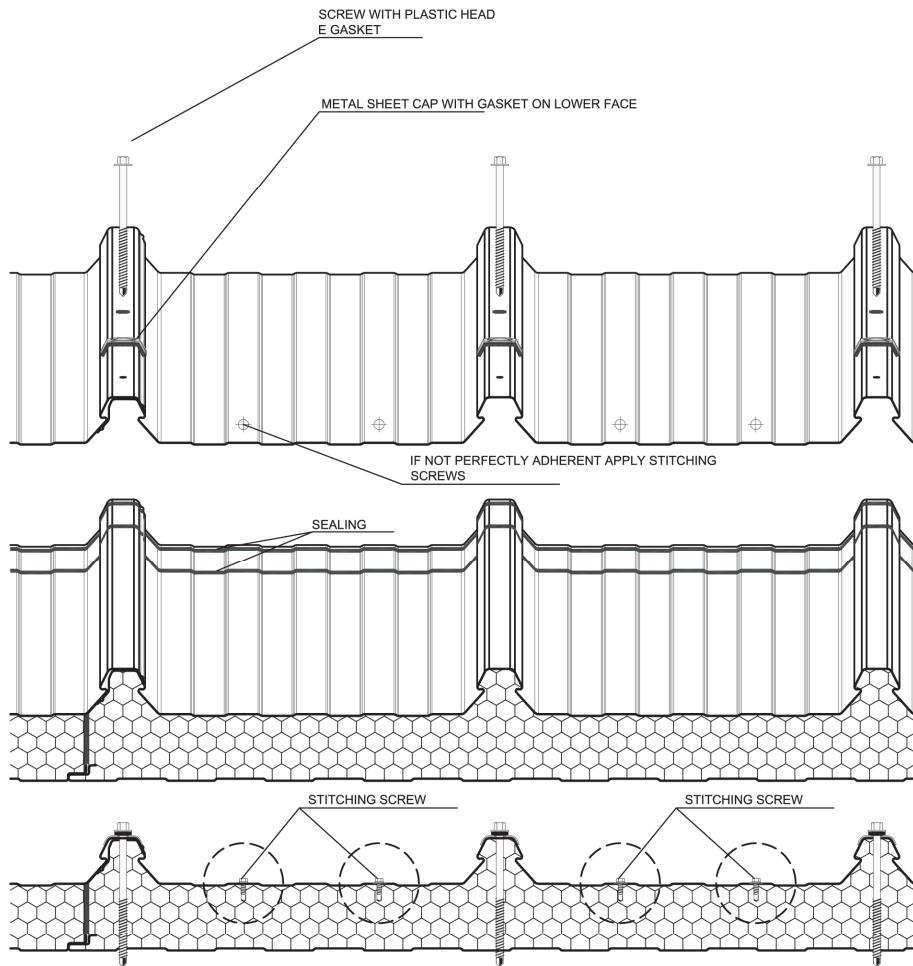

ATTENTION: the proposed solution does not represent a project, and must be examined and assessed prior by the designer or Clerk of Works. The property rights of this document belong exclusively to ISOPAN S.p.a. Reproduction even in part without prior written authorisation by the author is forbidden. To choose the type of fastening, please refer to the screw type choice sheet; To choose the screw length, please refer to the data sheet for the correct screw length.



PART OF
MANNI
GROUP



ISOPAN

INSULATING DESIGN

www.isopan.com



Copyright © - ISOPAN S.p.A.

ITALY

REGISTERED AND ADMINISTRATIVE HQ

Via Augusto Righi 7 |
37135 Verona | Italy
T. +39 045 8088911

ISOPAN SPA

Verona | Italy
T. +39 045 7359111

Frosinone | Italy
T. +39 07752081

WORLD

ISOPAN IBERICA

Tarragona | Spain
T. +34 977 52 45 46

ISOPAN EST

Popești Leordeni | Romania
T. +40 21 3051600

ISOPAN DEUTSCHLAND GmbH

OT Plötz | Germany
T. +49 3460 33220

ISOPAN RUS

Volgogradskaya oblast* | Russia
T. +7 8443 2120 30

ISOCINDU

Guanajuato | Mexico
+52 1472 800 7241

SALES OFFICES

ISOPAN FRANCE

Mérignac | France
T. +33 5 56021352

ISOPAN MANNI GROUP CZ

Praha | Czech Republic
contact@isopansendvicovepanely.cz